

Construction Industry Communication #23

From: Amit Ghosh, Chief Building Official
Re: 1, 2 and 3 Family Dwelling Decks and Exterior Egress Components
Date: July 17, 2017

Memorandum: Plan approval and building permits are required for alterations to the means of egress between the exit door and the level of exit discharge including landings, decks, ramps and stairs. The only exception is for decks not exceeding 200 square feet in area, that are not more than 30 inches above grade at any point, are not attached to the dwelling and do not serve the required exit door. However, a zoning approval is required for all decks exceeding 169 square feet regardless of the location or height.

Permits for landings, stairs or temporary ramps 30 inches or less above grade at any point may be issued as a minor limited scope permit and will require a final inspection when all work is complete.

Decks must comply with the following minimum provisions of the Residential Code of Ohio:

311.3.1 - The step from the dwelling onto the deck shall not exceed 8 ¼ inches when measured from the top of the door threshold to the deck surface provided the door does not swing out onto the deck.

311.7.4 – Stair Treads and Risers: Risers no more than 8 ¼ inch high, treads not less than 9 inches, open risers shall be permitted provided that the opening between treads does not permit the passage of a 4 inch sphere. Solid risers shall have a minimum ¾ inch to maximum 1 ¼ inch nosing.

311.7.7 - A handrail not less than 34 inches or more than 38 inches shall be provided on at least one side of the steps when there are 4 or more risers.

312.1 - A 36 inch high guardrail shall be provided on all decks where the grade is more than 30 inches to the deck surface when measured 3 feet out from the edge of the deck. The guardrail shall be provided along the edge of the deck surface and/or perimeter fixed seating

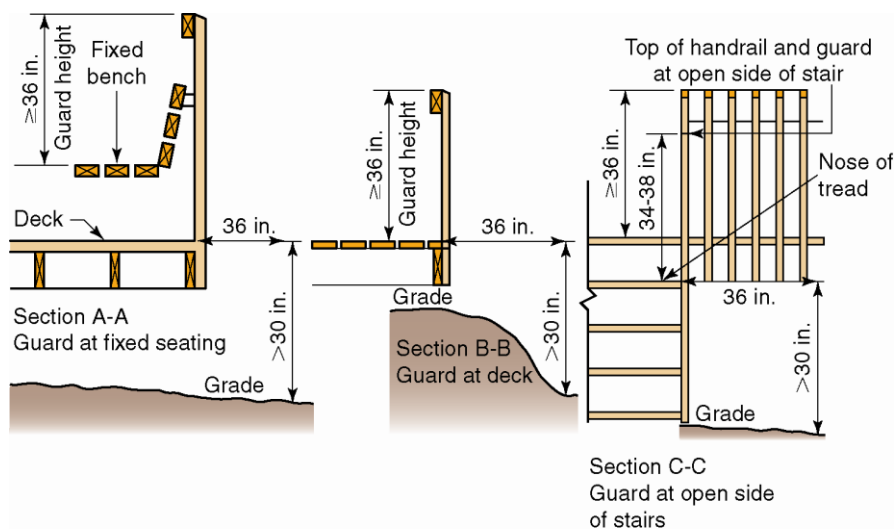

Determining required guard locations

502.2.2 Decks attached to the structure shall be designed and installed to resist both vertical and horizontal movement. Such attachment shall not be accomplished by the use of toenails or nails subject to withdrawal.

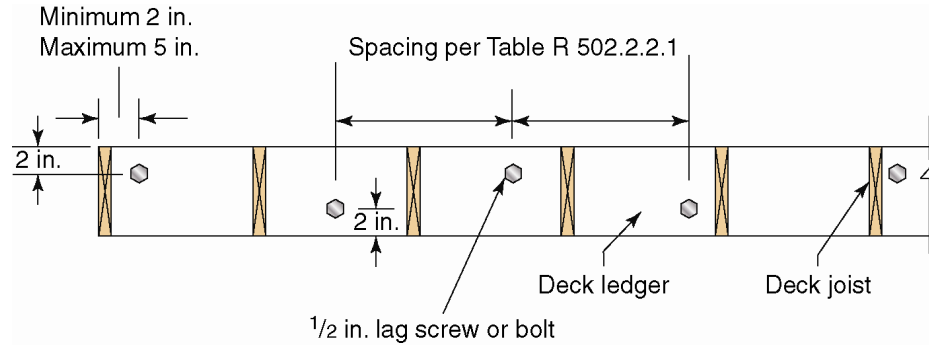

Deck ledger connection

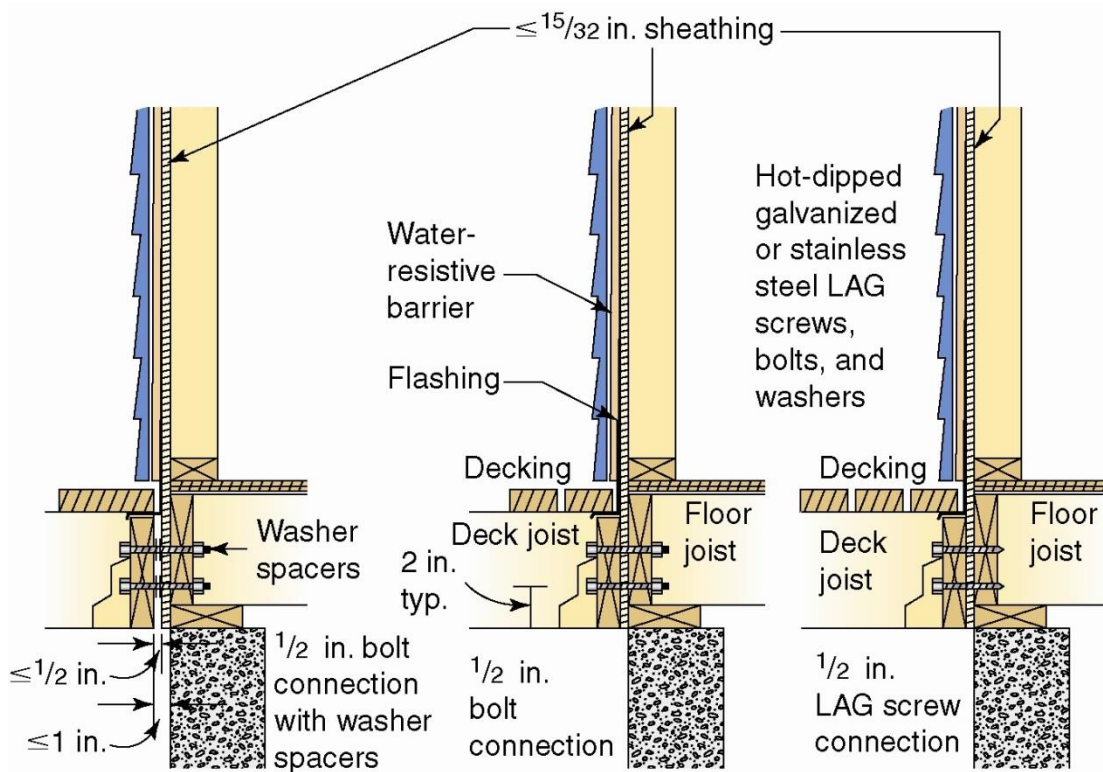

703.8 Approved corrosion-resistant flashing shall be provided in the exterior wall envelope in such a manner as to prevent entry of water into the wall cavity or penetration of water to the building structural components where porches, decks or stairs are attached to a wall or floor assembly of wood-frame construction.

For additional information on the requirements for permits, please call 614-645-7562 or visit our website at www.columbus.gov/bzs.