

Transmission & Distribution
Material & Installation Specification

24" Spacer Cable Tangent Bracket with
Anti-Sway Bracket, Tangent 5 or Less

I. Quantity

The base bid shall include the indicated number of 24" spacer cable tangent brackets with anti-sway bracket furnished and installed as hereinafter specified.

II. Material

- A. 24" spacer cable tangent bracket - Supplied with messenger clamp for 1/2 inch to 9/16 inch messenger. Hendrix BM-24 or approved equal.
- B. Ground Wire - The ground wire shall be #6 solid soft drawn bare copper.
- C. Connectors - copper compression type.
- D. Tangent Bracket Stirrup - Hot dipped galvanized. Hendrix TS-1 or approved equal.
- E. Spacer - High density polyethylene. Hendrix RTL-15 or approved equal.
- F. Anti-Sway Bracket - High density polyethylene. Hendrix BAS-14F or approved equal.
- G. All steel hardware to be hot dipped galvanized.

III. Installation

- A. The installation shall be as shown on drawing TDMIS-303.
- B. The 24" tangent bracket with anti-sway bracket shall be used to stabilize spacers, supporting the spacer cable, on tangent poles and line angles up to and including five (5) degrees.

- C. Typical applications are at transformer tap poles to stabilize the spacer, thus eliminating the flex of the transformer lead wire and to allow the spacer to remain vertical on poles with a slight angle up to and including 5 degrees.

IV. Method of measurement

Shall be per each completed assembly including bracket, bolts, washers, ground connections, tools, labor, equipment and all miscellaneous required for a complete and operational module.

V. Basis of payment

| Items | Unit | Description |
|-----------|------|---|
| TDMIS-303 | Each | 24" spacer cable tangent bracket with anti-sway bracket, tangent 5° or less |

| | | |
|---|------------------|------------------|
| CITY OF COLUMBUS DEPT. OF PUBLIC UTILITIES – DIVISION OF POWER 24" SPACER CABLE TANGENT BRACKET W/ ANTI-SWAY BRACKET, TANGENT 5° OR LESS | | |
| DRAWN BY: AEC | DATE: 01/01/2018 | TDMIS-303 |
| APPROVED: <i>[Signature]</i> | | |
| | SHEET 1 of 2 | |

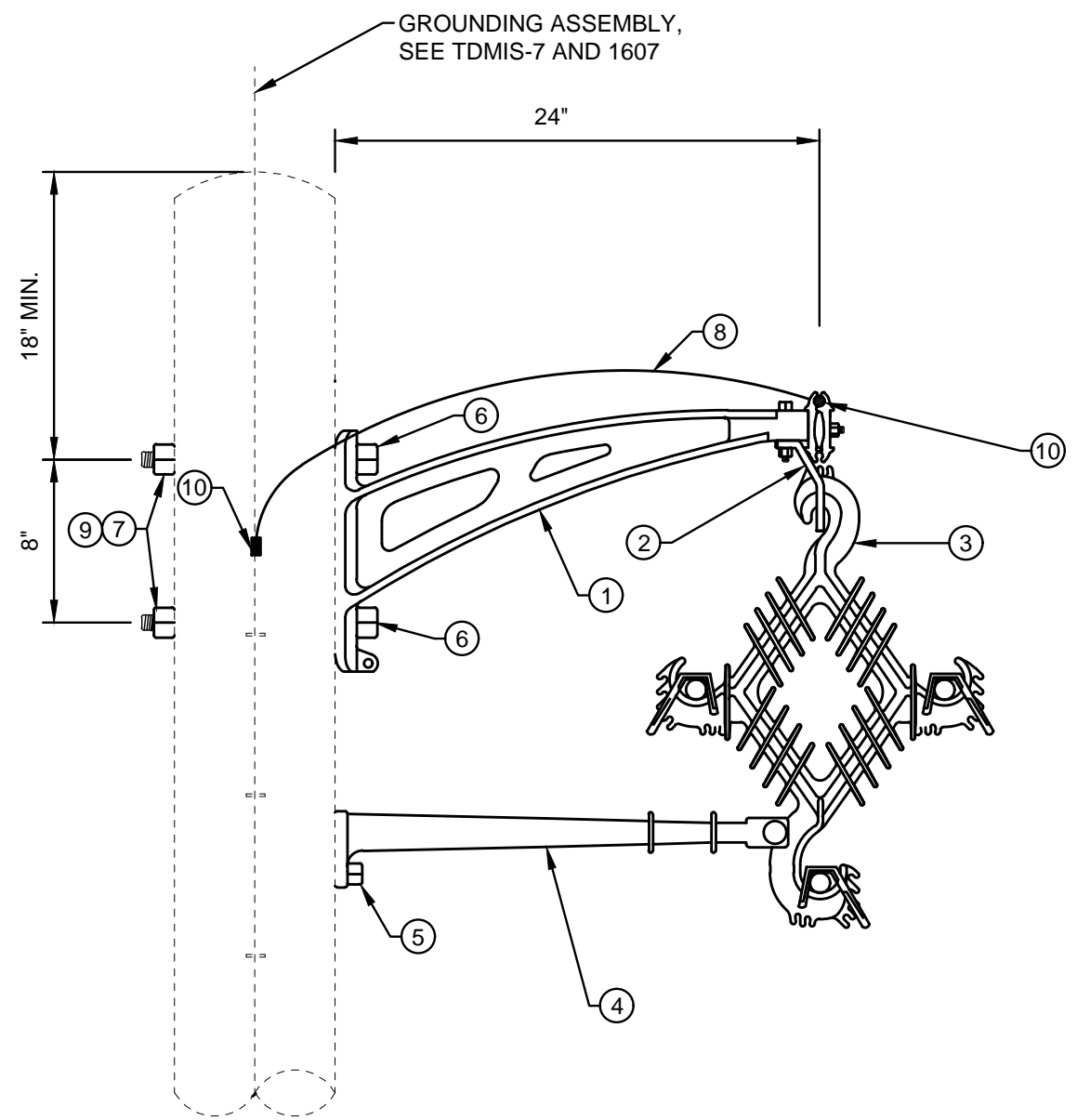

DETAIL 1
24" SPACER CABLE TANGENT BRACKET, WITH ANTI-SWAY BRACKET

REFERENCE LIST

| TDMIS | DESCRIPTION |
|-------|---|
| 1 | WOOD POLES |
| 7 | OVERHEAD DISTRIBUTION CIRCUIT GROUNDING |
| 1607 | GROUND ROD TEST |

ITEM LIST

| ITEM # | DESCRIPTION | PART # | QTY. |
|--------|---|--------|------|
| ① | MESSENGER BRACKET, HENDRIX TYPE BM-24 | 19650 | 1 |
| ② | STIRRUP, (HENDRIX TYPE TS-1), SUPPL. W/ 1/2" BOLT AND SELF-LOC. NUT | 20325 | 1 |
| ③ | SPACER WITH CLAMPS | 20322 | 1 |
| ④ | ANTI-SWAY BAR, HENDRIX TYPE BAS-24F, SUPPLIED WITH PLASTIC BOLT | 19646 | 1 |
| ⑤ | LAG SCREW, FETTER DRIVE, 1/2"X5" | 18985 | 1 |
| ⑥ | MACHINE BOLT, 5/8" X REQUIRED LENGTH | 42369 | 2 |
| ⑦ | SQUARE WASHER, 2 1/4"X2 1/4"X3/16" SQ. CURVED | 18897 | 2 |
| ⑧ | GROUND WIRE, SOFT DRAWN COPPER, SOLID, #6 CU | 20082 | 3 |
| ⑨ | WASHER, SPRING LOCK, DOUBLE COIL, GALVANIZED | 18895 | 2 |
| ⑩ | CONNECTOR, (SIZE AND TYPE AS REQUIRED) | 42373 | 2 |

CITY OF COLUMBUS, OHIO
 DEPT. OF PUBLIC UTILITIES - DIVISION OF POWER

**24" SPACER CABLE TANGENT BRACKET W/
 ANTI-SWAY BRACKET, TANGENT 5° OR LESS
 MSCBAS24**

DRAWN BY: AEC DATE: 01/01/2018

APPROVED: *[Signature]*

SCALE: NTS SHEET: 2 OF 2

TDMIS-303