

**Transmission & Distribution**  
**Material & Installation Specification**

**Spacer Cable to Spacer Cable Double Deadend on Crossarm**

**I. Quantity**

The base bid shall include the indicated number of spacer cable to open wire double deadend on crossarm furnished and installed as hereinafter specified.

**II. Material**

- A. Crossarm - Wood, 3 ½" x 4 ½" x 10'-0". Refer to TDMIS-10 or 11.
- B. Ground Wire - The ground wire shall be #6 solid soft drawn bare copper.
- C. Connectors - copper compression type.
- D. Preshaped type grip for messenger - For ½" messenger. Preformed Line Products #AWDE-4128
- E. Preshaped type grip for spacer cable - For 336 MCM spacer cable. Preformed Line Products #ND-0120.
- F. Preshaped type grip for spacer cable - For 556 MCM spacer cable. Preformed Line Products #ND-0123.
- G. 15kV Polymer Deadend Insulator - 5/8" diameter rod deadend insulator. 16" leakage distance. Ohio Brass #401015-0215.
- H. All steel hardware to be hot dipped galvanized.

**III. Installation**

- A. The installation shall be as shown on drawing TDMIS-305.

**IV. Method of measurement**

Shall be per each completed assembly including bracket, bolts, washers, ground connections, final sag adjustment, final guy adjustment, tools, labor, equipment and all miscellaneous required for a complete and operational module.

**V. Basis of payment**

Items	Unit	Description
TDMIS-305	Each	Spacer cable to spacer cable double deadend on crossarm

CITY OF COLUMBUS DEPT. OF PUBLIC UTILITIES – DIVISION OF POWER SPACER CABLE TO SPACER CABLE DOUBLE DEADEND ON CROSSARM		
DRAWN BY: AEC	DATE: 01/01/2018	<b>TDMIS-305</b>
APPROVED: <i>Kid</i>		
	SHEET 1 of 2	

**GENERAL NOTES:**

- FIRST SPACER 30'-0" FROM POLE.

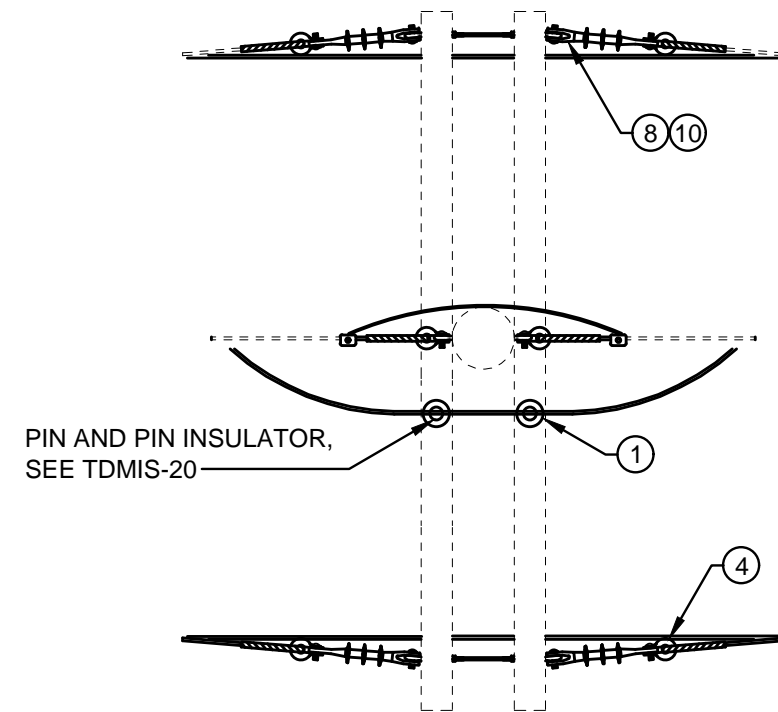

**DETAIL 1**  
**SPACER CABLE TO SPACER CABLE DOUBLE ENDED - PLAN VIEW**

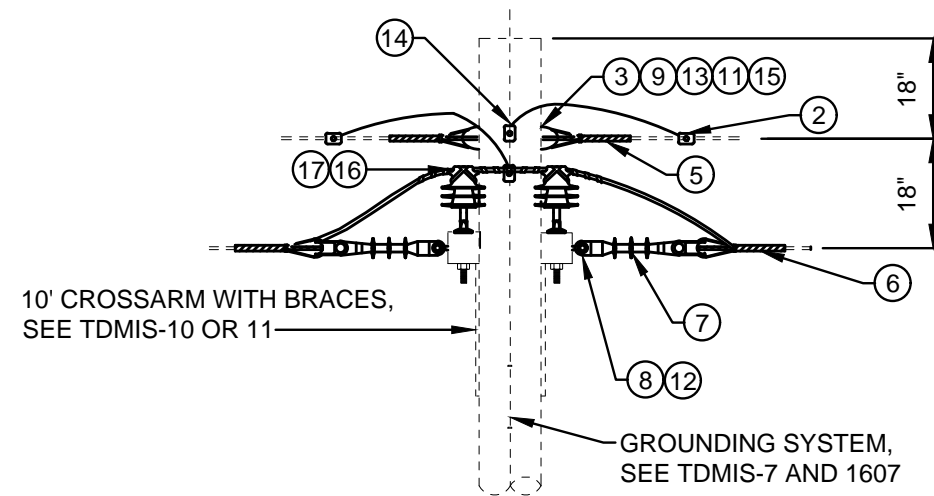

**DETAIL 2**  
**SPACER CABLE TO SPACER CABLE DOUBLE ENDED - SIDE VIEW**

**SCHEDULE**

ITEM #	SUFFIX NO.	DESCRIPTION	PART#
6	1	336MCM PREFORMED GRIP	20233
6	2	556MCM PREFORMED GRIP	20234

**ITEM LIST**

ITEM #	DESCRIPTION	PART #	QTY.
①	COVERED WIRE TIE, #4 SOLID SOFT DRAWN, ALUMINUM	20327	2
②	CONNECTOR, COMPRESSION, SIZE #6-#2/0	19629	3
③	DOUBLE ARMING BOLT, 3/4" X LENGTH AS REQ.	19103	1
④	THIMBLE CLEVIS (SPACER CABLE)	20228	6
⑤	PRESHAPED TYPE GRIP (MESSENGER)	19226	2
⑥	PRESHAPED TYPE GRIP (SPACER CABLE)	SEE SCH	6
⑦	INSULATOR, DEAD END TYPE, 15KV	20243	6
⑧	EYE NUT, STANDARD 5/8" (SPACER CABLE)	18977	6
⑨	SPRING LOCK WASHER, 13/16"	18894	2
⑩	SPRING LOCK WASHER, 11/16"	18893	5
⑪	WASHER, SQUARE CURVED, 4"X4"X1/4", 15/16" HOLE	18900	2
⑫	WASHER, FLAT, 2 1/4"X2 1/4"X3/16", 11/16" HOLE	18901	10
⑬	THIMBLE CLEVIS (MESSENGER)	20229	2
⑭	CONNECTOR, COMPRESSION, #6-#6	19628	3
⑮	EYE NUT, 3/4" (MESSENGER)	18978	2
⑯	INSULATOR, PIN TYPE, HENDRIX TYPE HPI-55-4	20256	2
⑰	PIN, INSULATOR, HENDRIX TYPE SSP-2	19307	2

**REFERENCE LIST**

TDMIS	DESCRIPTION
1	WOOD POLES
7	OVERHEAD DISTRIBUTION CIRCUIT GROUNDING
10	WOOD CROSSARM - WOOD BRACES
11	WOOD CROSSARM - STEEL BRACES
20	PIN AND PIN INSULATOR
1500	OVERHEAD CONDUCTOR, SPACER CABLE
1607	GROUND ROD TEST

CITY OF COLUMBUS, OHIO  
DEPT. OF PUBLIC UTILITIES - DIVISION OF POWER

**SPACER CABLE TO SPACER CABLE  
DOUBLE DEADEND ON CROSSARM  
MSCXDDE**

DRAWN BY: AEC DATE: 01/01/2018  
APPROVED: *[Signature]*  
SCALE: NTS SHEET: 2 OF 2

**TDMIS-305**