

**Transmission & Distribution**  
**Material & Installation Specification**

**Single Phase Primary Enclosure 200A**

**I. Quantity**

The base bid shall include the indicated number of Single Phase Primary Enclosures of this type furnished and installed as hereinafter specified.

**II. Material**

- A. The material shall be equal in quality, design, performance, and appearance to the items specified on drawing TDMIS-1400.
- B. This specification covers the minimum requirements for cable junction pedestals designed for single phase service application.
- C. Pedestal shall be made of fiberglass reinforced polymer with ¼” nominal thicknesses.
- D. All externally facing fiberglass reinforced polymer shall be gel coated. Gel coat color shall be Willow green (light) or Munsell green as approved by engineer.
- E. The fiberglass reinforced polymer shall be made with fire retardant resin and shall have a flammability rating of HB per UL-94.
- F. The fiberglass reinforced polymer shall be resistant to typical roadside chemicals. The fiberglass material shall conform to the chemical resistance criteria listed in the latest revision of ANSI/SCTE 77. Specimens shall be exposed to the chemicals as follows:

Chemical	Common Use	Concentration
Sodium Chloride	Road De-Icer	5%
Sulfuric Acid	Battery Acid	0.1N
Sodium Carbonate	Water Softener	0.1N
Sodium Sulfate	Detergents	0.1N
Hydrochloric Acid	Mineral Acid / Cleaner	0.2N
Sodium Hydroxide	Lye / Caustic Soda	0.1N

Acetic Acid	Solvent / Vinegar	5%
Kerosene	Jet Fuel	Per ASTM D543
Transformer Oil	Mineral Oil	Per ASTM D543
Magnesium Chloride	Road De-Icer	5%

- G. The pedestal locking device shall be of cast aluminum-bronze or silicon-bronze with captive 188 stainless steel hardware. The locking device shall have provisions for a padlock.
- H. The junction mounting assembly shall be made of 5000 or 6000 series aluminum, or 18-8 stainless steel. Parking clips shall be made of 18-8 stainless steel.
- I. All interior and exterior hardware shall be made of 18-8 stainless steel.
- J. The pedestal shall meet all criteria set forth in ANSI C57.12.28, Pad-mounted Equipment Enclosure Integrity Standard.
- K. The pedestal cover shall open 90° and base sidewalls shall be of cut-away type to allow unobstructed access to internal hardware.
- L. The pedestal base shall be designed to withstand a sidewall pressure of 130 psf (6.2 kPa) without cracking. This will simulate soil pressure placed on the pedestal.
- M. Both the pedestal base and cover shall be of a female mold design for security and aesthetic purposes.
- N. The pedestal shall have 4 lifting eyes for hoist slings.
- O. The cover shall be supplied with locking devices to prevent accidental closure. The weight of the cover is not sufficient to be considered a locking device.
- P. The junction mounting bar shall be designed to accommodate junctions and elbows which conform to IEEE 386.
- Q. The junction mounting assembly shall be able to withstand a 400 lb. (1780 N) pulling or pushing force along the cable junction axis anywhere along the mounting bar without damage or permanent distortion.
- R. The quantity of feed thru connectors, elbows, arresters, and other cable accessories shall be as required for the project and as approved by the engineer.

CITY OF COLUMBUS DEPT. OF PUBLIC UTILITIES – DIVISION OF POWER SINGLE PHASE PRIMARY ENCLOSURE 200A		
DRAWN BY: AEC	DATE: 01/01/2018	<b>TDMIS-1400</b>
APPROVED: <i>[Signature]</i>		
	SHEET 1 of 3	

S. Grounding shall be as required by TDMIS-1213 and TDMIS-1607.

**III. Installation**

- A. The installation shall be as shown on drawing TDMIS-1400.
- B. Cabinet shall be installed on a concrete pad, composite pad, or composite ground sleeve as required by project specifications and drawings.
- C. Installation shall include all labels, tags and stickers required by DOP.
- D. Cabinets shall be installed level and plumb. When installed on ground sleeves over direct buried cable trenches, care shall be taken that cabinet is positioned over undisturbed soil alongside the trench to avoid settlement.

**IV. Method of measurement**

Shall include cabinet and all mounting and locking hardware, installation, ground sleeves, anchors, excavation, backfill, final grading, seed or sod, grounding, labor, equipment, supervision, and miscellaneous items required for a complete and operational enclosure.

**V. Basis of payment**

Items	Unit	Description
TDMIS-1400	Each	Single phase primary enclosure, 200A

CITY OF COLUMBUS DEPT. OF PUBLIC UTILITIES – DIVISION OF POWER SINGLE PHASE PRIMARY ENCLOSURE 200A		
DRAWN BY: AEC	DATE: 01/01/2018	TDMIS-1400
APPROVED: <i>[Signature]</i>		
	SHEET 2 of 3	

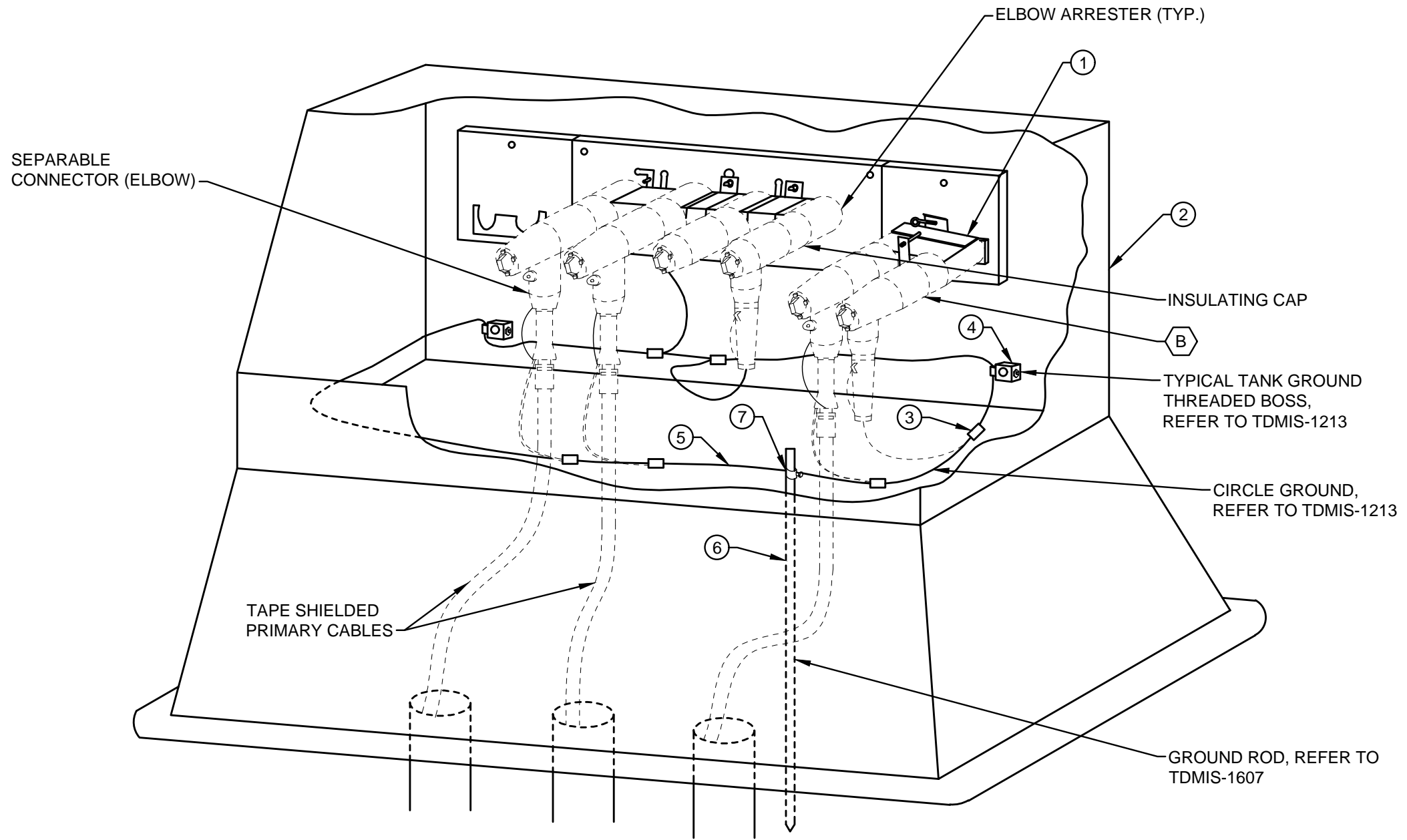
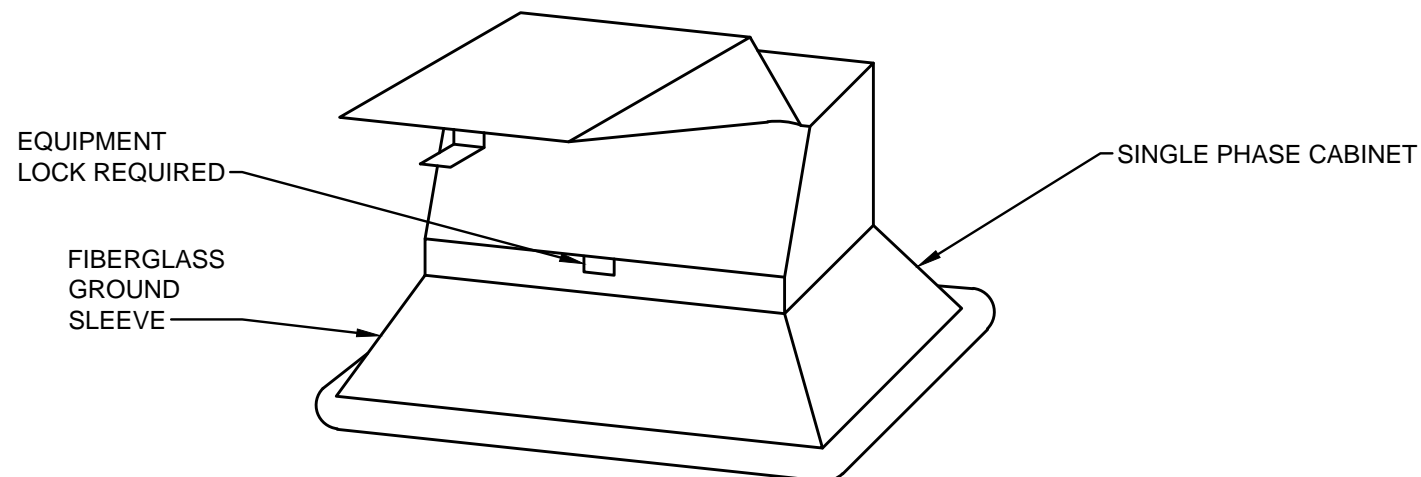

### REFERENCE LIST

TDMIS	DESCRIPTION
1213	CIRCLE GROUND ASSEMBLY
1607	GROUND ROD TEST

### ITEM LIST

ITEM #	DESCRIPTION	PART #	QTY.
①	FEED THRU	*	3
②	SINGLE PHASE PRIMARY ENCLOSURE	*	1
③	CONNECTOR, COMPRESSION TYPE	*	AS REQ
④	CONNECTOR, BRONZE AERIAL TYPE	*	2
⑤	CONDUCTOR, #6 SOLID, SOFT DRAWN COPPER	20083	AS REQ
⑥	ROD, GROUND 5/8"X10" COPPERWELD	*	1
⑦	ACORN CLAMP	20431	1

CITY OF COLUMBUS, OHIO  
DEPT. OF PUBLIC UTILITIES - DIVISION OF POWER

### SINGLE PHASE PRIMARY ENCLOSURE 200A

DRAWN BY: AEC	DATE: 01/01/2018	TDMIS-1400
APPROVED: <i>[Signature]</i>		
SCALE: NTS	SHEET: 3 OF 3	

**DETAIL 1**  
**SINGLE PHASE PRIMARY ENCLOSURE 200A**