

***** THIS STANDARD REPLACES FORMER TDMIS-1005, 1006, AND 1213 *****

3800. GENERAL

The following TDMIS is the practice to be followed when designing and installing Underground Commercial or Residential Distribution (URD/UCD). This standard shall apply to primary and secondary systems installed by both DOP and/or the customer/developer.

3801. CLEARANCE FROM BUILDINGS AND OBJECTS

Air insulated equipment shall have a 5 foot minimum clearance from buildings. In the absence of industry accepted or municipal requirements, oil insulated equipment shall be located in compliance with the minimum clearances indicated in Section 3801.1. For existing buildings, the transformer shall not block access to existing building systems, such as wall mounted fire sprinkler systems. The building owner’s and/or tenant’s fire insurance carrier or local inspection authority may restrict the proximity of the equipment to doors, windows or combustible materials. It is the customer/developer’s responsibility to determine the acceptability of the proposed location of the equipment.

The clearances, line of sight, shall apply to doorways, windows, ventilation ducts and fire escapes.

TDMIS 3800 – UNDERGROUND DEVELOPMENTS			
	DIVISION OF POWER TRANSMISSION AND DISTRIBUTION MATERIAL AND INSTALLATION SPECIFICATIONS	ISSUE	NUMBER
		12/19	3801

SECTION 3800 – UNDERGROUND DEVELOPMENTS

3801.1. Clearances from Buildings

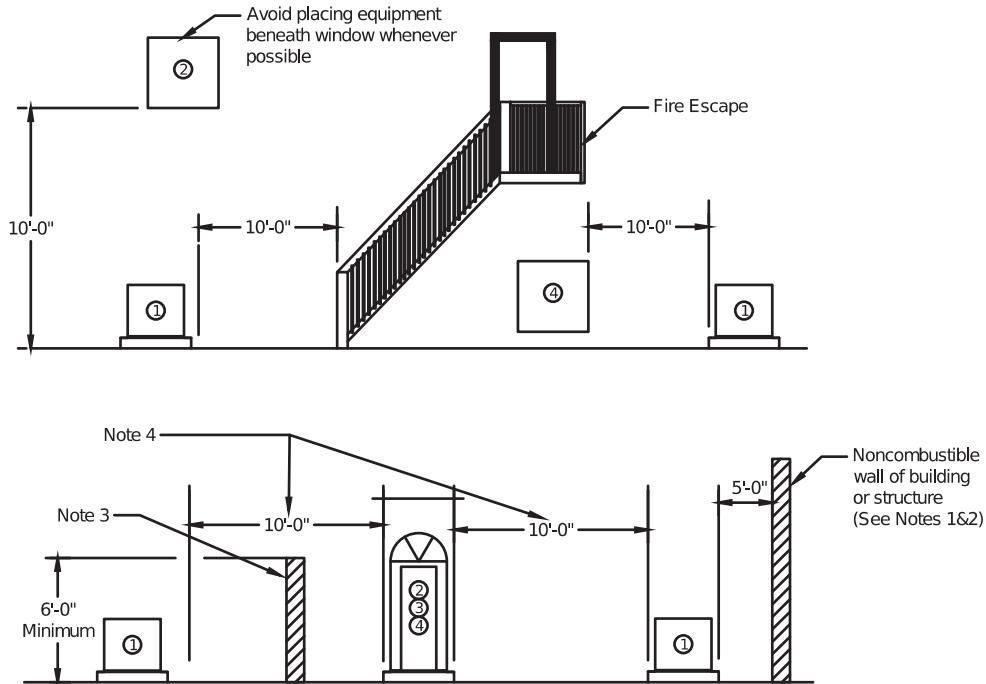

Figure 3801-1: Transformer Clearance from Buildings and Structures

Legend	
①	Equipment, oil insulated
②	Window
③	Door
④	Ventilating Duct

Figure Notes:

1. Noncombustible material is defined as a material that will not ignite, burn, support combustion or release flammable vapors, when subjected to fire or heat, or as described by the latest edition of the NFPA-220.
2. No portion of a building or building structure shall overhang any part of the pad-mounted equipment, subject to the exemption described in Note 3.
3. In cases where required distances cannot be met a noncombustible barrier or structure shall be constructed. This barrier shall be designed to provide adequate fire protection to the existing structure. A design for this structure shall be prepared and sealed by the customer's

TDMIS 3800 – UNDERGROUND DEVELOPMENTS			
NUMBER	ISSUE	DIVISION OF POWER TRANSMISSION AND DISTRIBUTION MATERIAL AND INSTALLATION SPECIFICATIONS	THE CITY OF COLUMBUS DEPARTMENT OF PUBLIC UTILITIES
3801	12/19		

SECTION 3800 – UNDERGROUND DEVELOPMENTS

Professional Engineer or Registered Architect and shall be further approved by the local authority having jurisdiction of building code enforcement.

- 4. For exits from a public assembly room, such as an auditorium, a 10 foot minimum clearance should be increased to 25 feet, unless there is a barrier.

3801.2. Clearances from Objects

An area measuring 10 feet from any point of the transformer pad shall be kept free of all:

- 1. buried water lines, storm drain lines, gas lines, sewer lines and other electric lines;
- 2. underground fuel storage tanks;
- 3. above grade fire hydrants, cell towers, self-contained diesel or diesel byproduct fuel; and
- 4. generators and outdoor enclosed generators.

An area measuring 25 feet from any point of the transformer pad shall be kept free of all:

- 1. exposed water lines, gas piping, sewer lines;
- 2. open conductor electric lines; and
- 3. above-grade gas meters or regulator vents, fuel storage tanks or dispensing units, and non-enclosed gasoline fueled generators.

The 25-foot clearance may be reduced to 10 feet with a noncombustible barrier (see Note 3 in Section 3801.1) and shall not be less than 5 feet from the edge of the transformer pad. The customer or their authorized representative shall obtain this clearance reduction approval from DOP and the local authority having jurisdiction as necessary, prior to the noncombustible barrier installation

3802. ACCESSIBILITY

Equipment shall be located within 10 feet of a way open to vehicular traffic and a minimum distance from any structure such as poles, fences, etc. as a means to permit accessibility for installation and maintenance. A minimum of 10 feet of clear space shall be maintained in

TDMIS 3800 – UNDERGROUND DEVELOPMENTS			
THE CITY OF COLUMBUS DEPARTMENT OF PUBLIC UTILITIES	DIVISION OF POWER TRANSMISSION AND DISTRIBUTION MATERIAL AND INSTALLATION SPECIFICATIONS	ISSUE	NUMBER
		12/19	3802

SECTION 3800 – UNDERGROUND DEVELOPMENTS

front of the equipment doors to permit installation and removal of separable connectors and fuses with shotgun stick.

3803. MECHANICAL PROTECTION

Whenever possible, equipment should be located so it is not subject to vehicular damage. If this is not feasible, adequate guards such as concrete filled pipes or bollards shall be placed to protect the equipment. Refer to TDMIS-3816 for details.

3804. NOISE LEVEL

When locating transformers or other equipment, consideration should be given to the effect of noise on adjacent occupancies.

3805. FINISHED GRADE

Finish grade shall slope away from building.

3806. EASEMENTS

Requirements for underground construction and associated pad-mounted equipment shall be determined for each site by DOP Engineering. All DOP-owned equipment must be located within a permanent easement. The customer/developer shall grant such permanent easements, including rights of access to each easement, to the City of Columbus. Easements must be in place prior to installation of any DOP-owned equipment.

3807. CLEAN FILL CERTIFICATION

The customer/developer shall certify, to DOP, that areas in which DOP is to perform installation or maintenance work are free of pre-existing contamination by hazardous wastes or materials and indemnify the City of Columbus for any claims, costs, expenses, suits, demands, citations, fines, or damages of any kind arising from the presence of any such contamination.

TDMIS 3800 – UNDERGROUND DEVELOPMENTS			
NUMBER	ISSUE	DIVISION OF POWER TRANSMISSION AND DISTRIBUTION MATERIAL AND INSTALLATION SPECIFICATIONS	THE CITY OF COLUMBUS DEPARTMENT OF PUBLIC UTILITIES
3803	12/19		

SECTION 3800 – UNDERGROUND DEVELOPMENTS

3808. TRENCH AND DUCTLINE

Trenches and ductline installation shall be in accordance with TDMIS-3000 – Conduit.

3809. RISER POLE

DOP shall designate conduit riser locations on the pole. Riser pole installation and maintenance shall be in accordance with TDMIS-1001 – Primary Riser Pole.

3810. SWITCH / SWITCHGEAR

DOP shall designate switches and switchgear locations. Switchgear installation and maintenance shall be in accordance with TDMIS-1016 – Precast Switchgear Manhole and TDMIS-1406 – Pad-Mounted SF6 Gas Primary Switch.

3811. PAD-MOUNTED TRANSFORMER INSTALLATION

The type and size of pad-mounted transformers shall be determined by DOP Engineering. Installation and grounding shall be in accordance with all applicable subsections of TDMIS-3800, TDMIS-9221, and TDMIS-9222. Dimensional information can also be found in TDMIS-3851 and TDMIS-3852. The transformer in most instances is to be installed, owned and maintained by DOP. Special ownership arrangements shall be referred to DOP Engineering.

DOP shall inspect the aggregate fill base for the transformer foundation prior to the foundation being placed. If a cast-in-place pad is used, DOP shall inspect the wood forms prior to pouring the foundation. DOP shall perform a final inspection after the foundation is poured or set.

3812. PRIMARY AND SECONDARY CABLE TERMINATIONS

In general, jacketed cable per TDMIS-1510, cold shrink terminators, and loadbreak elbows per TDMIS-1100 shall be specified. DOP Engineering shall size and specify cable for special designs. DOP will furnish, install, own and maintain all primary cable and terminations. Ground all primary bushing inserts as shown in Figure 3812-1. A minimum of #14 solid copper or equivalent shall be used to bond bushing insert to mounting plate.

TDMIS 3800 – UNDERGROUND DEVELOPMENTS			
	DIVISION OF POWER TRANSMISSION AND DISTRIBUTION MATERIAL AND INSTALLATION SPECIFICATIONS	ISSUE	NUMBER
		12/19	3812

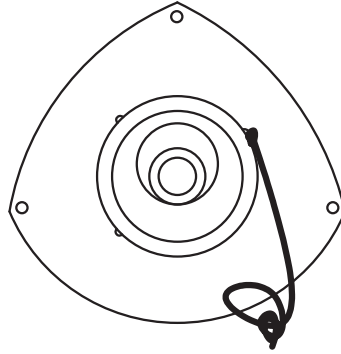



Figure 3812-1: Primary Bushing Grounding Detail (One phase shown)

3813. SECONDARY CABLES

Secondary cables shall be installed underground in customer/developer furnished, installed, owned and maintained conduit system or raceway. Conditions requiring more secondary cables than DOP’s transformer secondary terminals can accommodate may require the customer/developer to supply an intermediate secondary cable collecting bus to make a transition from National Electrical Code required cable capabilities (required to match main switch), to actual load cable capabilities. The need for any additional secondary connector bus pad-mounted compartment shall be determined by DOP Engineering.

3813.1. Three-Phase Pad-Mounted Transformers

Size and number of customer-owned secondary cables shall be in accordance with the NEC and shall be approved by the local electrical inspector. Maximum number of secondary cables to be physically connected to DOP’s pad-mounted transformer is outlined in Table 3813-1.

TDMIS 3800 – UNDERGROUND DEVELOPMENTS			
NUMBER	ISSUE	DIVISION OF POWER TRANSMISSION AND DISTRIBUTION MATERIAL AND INSTALLATION SPECIFICATIONS	
3813	12/19		

SECTION 3800 – UNDERGROUND DEVELOPMENTS

Number of Spade Holes	Max. Size and Number of Cables	
	Compression Type Connectors	Bolted or Set Screw Type Connectors
4	4 sets of 750 MCM	6 sets of 500 MCM
6	6 sets of 750 MCM	8 sets of 500 MCM* 6 sets of 750 MCM
8	8 sets of 750 MCM	10 sets of 750 MCM
10	10 sets of 750 MCM	10 sets of 750 MCM
* Transformers smaller than 750 kVA are limited to six sets of conductors.		

Table 3813-1: Max. Number of Secondary Cables by Number of Spade Holes

Secondary requirements greater than this shall necessitate a separate compartment, pull box, or bus duct, and should be referred to DOP Engineering. Minimum terminal thickness is to be 1/4-inch, with 9/16-inch holes.

3814. SECONDARY CONNECTIONS

All connectors and connector fasteners for use on customer-owned cable shall be furnished, installed, owned and maintained by the customer/developer. Connectors shall be approved by DOP prior to purchase. Final electrical connection to the transformer secondary terminals shall be inspected by DOP. The customer/developer shall make finger-tight connections to the spades of the pad-mount transformer. The customer/developer shall supply aluminum connectors for use with aluminum cable or bronze connectors for use with copper cable. Tin-plated connectors may also be used as an alternate connector for aluminum and bronze connectors.

Connector shall be a cable to flat clamp or compression type connector, with a minimum of two holes in the flat pad and two clamping elements or two compressions per cable. The clamping elements may be bolted or set-screw type. Examples acceptable connectors are shown in Figure 3814-1.



TDMIS 3800 – UNDERGROUND DEVELOPMENTS			
	DIVISION OF POWER TRANSMISSION AND DISTRIBUTION MATERIAL AND INSTALLATION SPECIFICATIONS	ISSUE	NUMBER
		12/19	3814

SECTION 3800 – UNDERGROUND DEVELOPMENTS

Figure 3814-1: Examples of Acceptable Spade Connectors

3814.1. Bolted Connections

All connecting bolts shall be ½”-13 aluminum 6061 T6 hex head bolts. Nuts and washers shall match the bolt material.

3814.1.1. Installation Instructions

1. A flat washer is placed between the concave side of the belleville washer and the surface of the member being joined. The belleville is thus captured between the head of the ½-inch bolt and the large flat washer. The flat washer should have an outside diameter greater than the flattened belleville’s such that no overhand results. Select a flat washer that is twice as thick as the belleville for strength. (If not available, stack two or three thinner washers to achieve the same effect).
2. With the belleville washer captured between the flat washer and the bolt head, fit the assembly into its hole. When the washers are fitted in position, there should be no interference with washers of adjacent bolts and no overhang over surface edges.
3. Tighten the nut on the bolt (with a washer of its own) until a sudden, noticeable increase in torque is required to continue. The belleville washer is now flat. It is not necessary to “back off” the nut after tightening to this point.

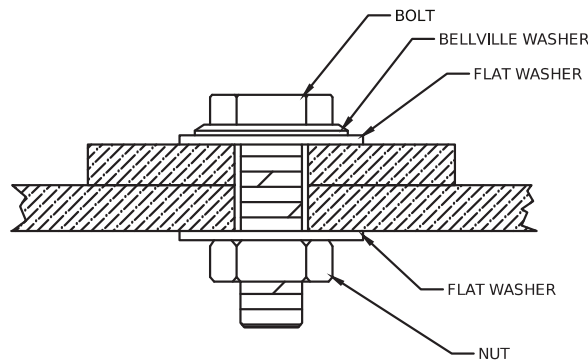



Figure 3814-2: Bolted Connection Detail

TDMIS 3800 – UNDERGROUND DEVELOPMENTS			
NUMBER	ISSUE	DIVISION OF POWER TRANSMISSION AND DISTRIBUTION MATERIAL AND INSTALLATION SPECIFICATIONS	
3814	12/19		

SECTION 3800 – UNDERGROUND DEVELOPMENTS

3815. METERING

Meter location and type shall be determined by DOP. Meters shall be furnished and installed by DOP.

3816. BOLLARDS

Bollards shall consist of 6 inch minimum diameter hot dip galvanized or painted steel pipes filled with concrete. Plastic bollard covers are available if bollard cannot be painted at the time of installation. Bollards are to be 5 feet above the ground and a minimum of 4 feet below the ground. Concrete is to be crowned on top of all bollards. Bollards are to be set in a 12” minimum concrete footing from the base to within 6” from finished grade. See TDMIS-3854 for details.

The number and locations of bollards shall be determined by DOP Engineering, taking into account proximity to traffic and to buildings as well as other barriers to traffic. Suggested bollard locations and dimensions are shown in TDMIS-38530. DOP Engineering will determine which bollards are required by marking TDMIS-3853 as described in Note 2. The location of bollards shall not impede a door opening of 100 degrees.

Bollards shall be installed with due care to avoid interfering with ground grid and conduits. TDMIS-9221 and TDMIS-9222 for concrete pad dimensions.

3817. CONCRETE PAD

Concrete shall conform to TDMIS-3011 for ready mix concrete. All exposed edges shall have a ¾ inch chamfer.

3818. REINFORCING

Reinforcing to be #5 grade 60 bars and shall conform to ASTM STANDARD A-615 of latest date. Reinforcing rods are to be located in center of the slab, with a minimum of 2 inches of clearance from face of concrete.

TDMIS 3800 – UNDERGROUND DEVELOPMENTS			
	DIVISION OF POWER TRANSMISSION AND DISTRIBUTION MATERIAL AND INSTALLATION SPECIFICATIONS	ISSUE	NUMBER
		12/19	3818

SECTION 3800 – UNDERGROUND DEVELOPMENTS

3819. SAND AND GRAVEL

Concrete slab shall be placed on an aggregate base of crushed limestone that meets the Ohio State Department of Transportation Standard 304 as shown on TDMIS-9221 or TDMIS-9222. The aggregate shall be thoroughly compacted to at least 95% and thoroughly wetted immediately before placing the concrete.

3820. PRECAST / POURED SLAB AND CONDUIT ENTRY

1. Conduit shall be installed as shown on TDMIS-9221 or TDMIS-9222 before slab is poured. Use 36-inch radius sweeps, with couplings, nipples and bushings as required. Sweeps for primary cables shall be galvanized steel or PVC.
2. Conduits shall be raised a minimum of 1 inch over the concrete slab and capped with an end bell (TDMIS Item UK6E). Expanding foam shall be used to fill the conduits around the cables and completely fill any empty conduits to prevent oil from entering the conduit in the event of a leak. A rag should be placed into empty conduits prior to the foam as a support for the foam while curing takes place. Sealing of conduits shall be done by the owner of the cables in the conduits. Additional information on installation and maintenance of conduit shall be in accordance with Section 3000 – Conduit.
3. After the concrete is cured, the remainder of the conduit primary and secondary openings through pad shall be sealed with grout. The conduit primary and secondary openings shall be filled with sand (no aggregate) to a grade of 4 inches below the top of the concrete pad. A layer of concrete grout (no aggregate) shall be placed 1 to 2 inches thick on top of the sand layer to seal the conduit entrance. The conduit ground clamps shall not be covered with grout. Expanding foam can also be used as an alternate to filling in the conduit area with sand and sealing the top with grout. Sealing of the openings shall be done by the installer of the pad and conduits.

3821. GROUND GRID

The ground grid shall be 2/0, bare, soft drawn, 19 strand copper wire. The wire shall be installed 12 inches below grade and located around the transformer pad as shown on TDMIS-3856. The grid shall be bonded to all exposed metallic conduit, and 3 feet of wire shall be left above pad for grounding transformer, one lead in the primary conduit opening

TDMIS 3800 – UNDERGROUND DEVELOPMENTS			
NUMBER	ISSUE	DIVISION OF POWER TRANSMISSION AND DISTRIBUTION MATERIAL AND INSTALLATION SPECIFICATIONS	THE CITY OF COLUMBUS DEPARTMENT OF PUBLIC UTILITIES
3819	12/19		

SECTION 3800 – UNDERGROUND DEVELOPMENTS

and the other lead in the secondary conduit opening. The neutrals from the cables connecting to ground grid shall be a compression type connector. Up to three separate neutrals from the cables can be bundled together at compression connector.

Two 5/8-inch diameter, 8-foot long copper weld ground rods and approved connectors shall be installed. The top of the ground rods shall be below finish grade. Leave the ground rods and grid exposed until inspected by DOP. The ground grid is to be complete and backfilled prior to energizing the transformer.

Connections to ground grid to be made as shown on TDMIS-3856, except that exothermic welding (“cad weld”) shall be an acceptable alternative to compression or bolted connections. Bolted connectors are only acceptable for the connections to the ground rods.

3822. OIL CONTAINMENT

This is to be used where oil containment is required by local authorities or where otherwise justified. This liner system will significantly slow the migration of oil into the under laying sub grade, allowing additional time to initiate a cleanup response. The polypropylene geotextile allows the passage of water but absorbs small quantities of oil.

This design is intended to confine 100% of total transformer oil present, with a 20% reserve margin, for up to 36 hours. If additional confinement is desired consult DOP Engineering.

Oil curb should be installed with concrete with a minimum 28-day strength of 3,000 psi. The maximum aggregate nominal size shall be 1-1/2 inch, and slump shall be no more than 2 inches. Reinforcement to be four #4, grade 60 rods, 6 inches on center as shown. Bend rods around corners. Fill area between slab and curb with 1½ inches uniformly graded crushed rock and line with 2 layers of geotextile liner as shown. Geotextile liners to be separated by a 6 inch layer of well compacted, silty sand and gravel mix. Geotextile liner shall be 16 oz. polypropylene geotextile - all seams to overlap a minimum of 12 inches.

See TDMIS-3855 for construction detail.

3823. CABLE TAGS

Primary cables shall be identified in each pull box, hand hole, manhole, vault, enclosure, riser pole, transformer and switchgear and at every termination point. Identification shall be a minimum of the circuit number, next location, and phase marking. For cables of one circuit that are bundled together, one tag can be used to indicate the circuit and location on

TDMIS 3800 – UNDERGROUND DEVELOPMENTS			
	DIVISION OF POWER TRANSMISSION AND DISTRIBUTION MATERIAL AND INSTALLATION SPECIFICATIONS	ISSUE	NUMBER
		12/19	3823

SECTION 3800 – UNDERGROUND DEVELOPMENTS

the bundled set of cables. The phase shall be included at terminations. In three phase loop feed transformers, the bushing (H1A, H2A, etc.) shall be included.

3824. FAULT INDICATORS

Fault indicators can be used in underground commercial distribution. The indicators can be installed in switchgears and pad-mounted transformers at the cable termination points. DOP Engineering can provide recommendations on where the indicators shall be used.

3825. UNDERGROUND RESIDENTIAL DISTRIBUTION

The customer is responsible for supplying and installing all conduit, pull boxes, hand holes, manholes, vaults, risers, and transformer pads, as specified by DOP. DOP will supply and install all electrical facilities including primary, secondary, and service cables.

Refer to TDMIS-1009 for materials and installation of single-phase pad-mounted transformers for use in residential distribution.

3826. MEASUREMENT AND PAYMENT

3826.1. Method of Measurement

The method of measurement shall include all equipment, accessories, structural fill, labor, equipment, tools, supervision, and miscellaneous required for a complete and operational assembly.

TDMIS 3800 – UNDERGROUND DEVELOPMENTS			
NUMBER	ISSUE	DIVISION OF POWER TRANSMISSION AND DISTRIBUTION MATERIAL AND INSTALLATION SPECIFICATIONS	THE CITY OF COLUMBUS DEPARTMENT OF PUBLIC UTILITIES
3824	12/19		

SECTION 3800 – UNDERGROUND DEVELOPMENTS

3826.2. Basis of Payment

Items	Unit	Description
TDMIS-3811	each	Fully installed concrete pad for three-phase transformer (75 to 500 kVA)
TDMIS-3811	each	Fully installed concrete pad for three-phase transformer (750 to 2500 kVA)
TDMIS-3816	each	Concrete-filled steel bollard
TDMIS-3822	each	Oil containment installation

TDMIS 3800 – UNDERGROUND DEVELOPMENTS			
	DIVISION OF POWER TRANSMISSION AND DISTRIBUTION MATERIAL AND INSTALLATION SPECIFICATIONS	ISSUE	NUMBER
		12/19	3826

SECTION 3800 – UNDERGROUND DEVELOPMENTS

3851. PRECAST CONCRETE TRANSFORMER PAD – 75 TO 500 KVA

Refer to TDMIS-9221 for full specifications. This drawing is intended for reference only.

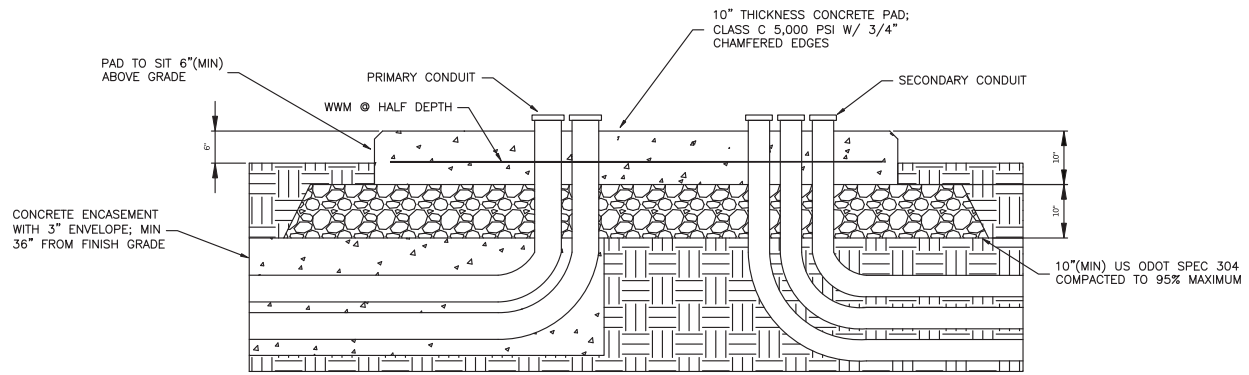
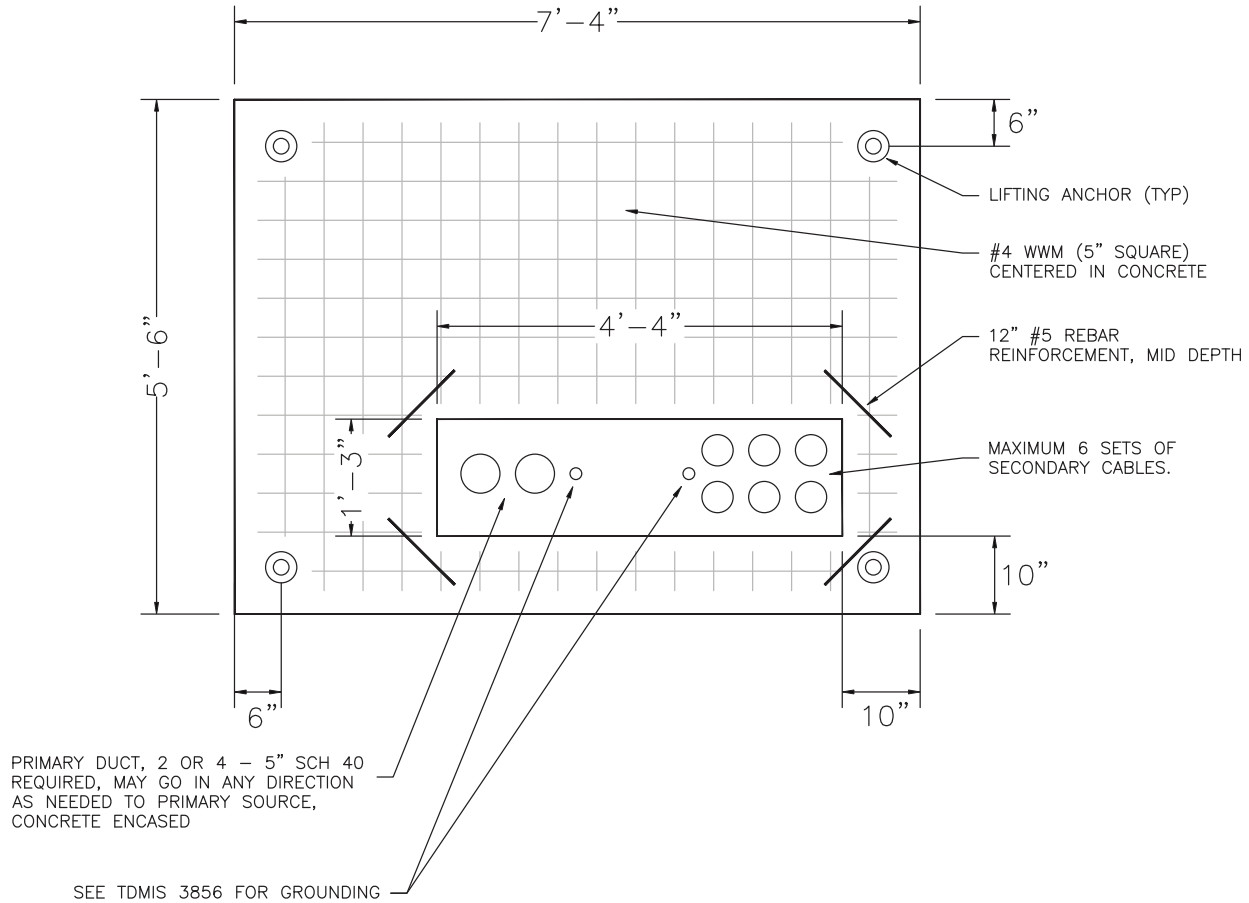

TDMIS 3800 – UNDERGROUND DEVELOPMENTS			
NUMBER	ISSUE	DIVISION OF POWER TRANSMISSION AND DISTRIBUTION MATERIAL AND INSTALLATION SPECIFICATIONS	
3851	12/19		

SECTION 3800 – UNDERGROUND DEVELOPMENTS

3852. PRECAST CONCRETE TRANSFORMER PAD – 750 TO 2500 KVA

Refer to TDMIS-9222 for full specifications. This drawing is intended for reference only.

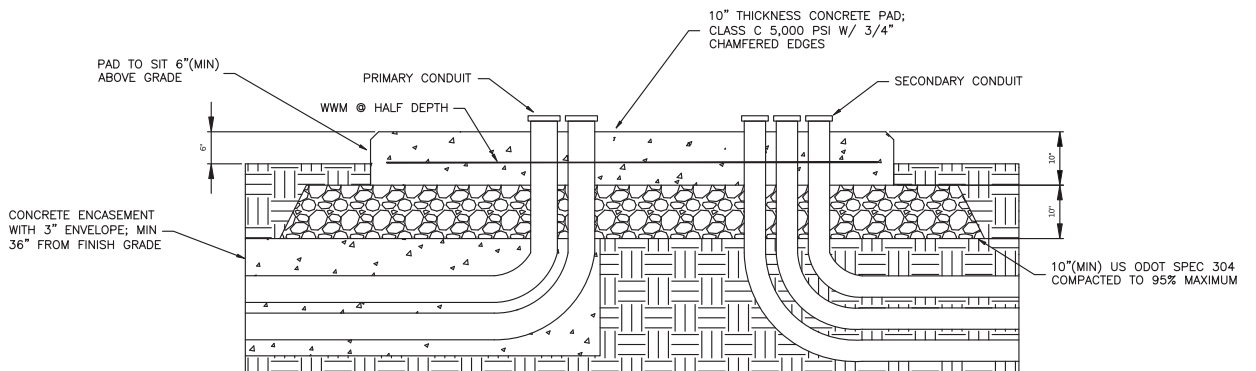
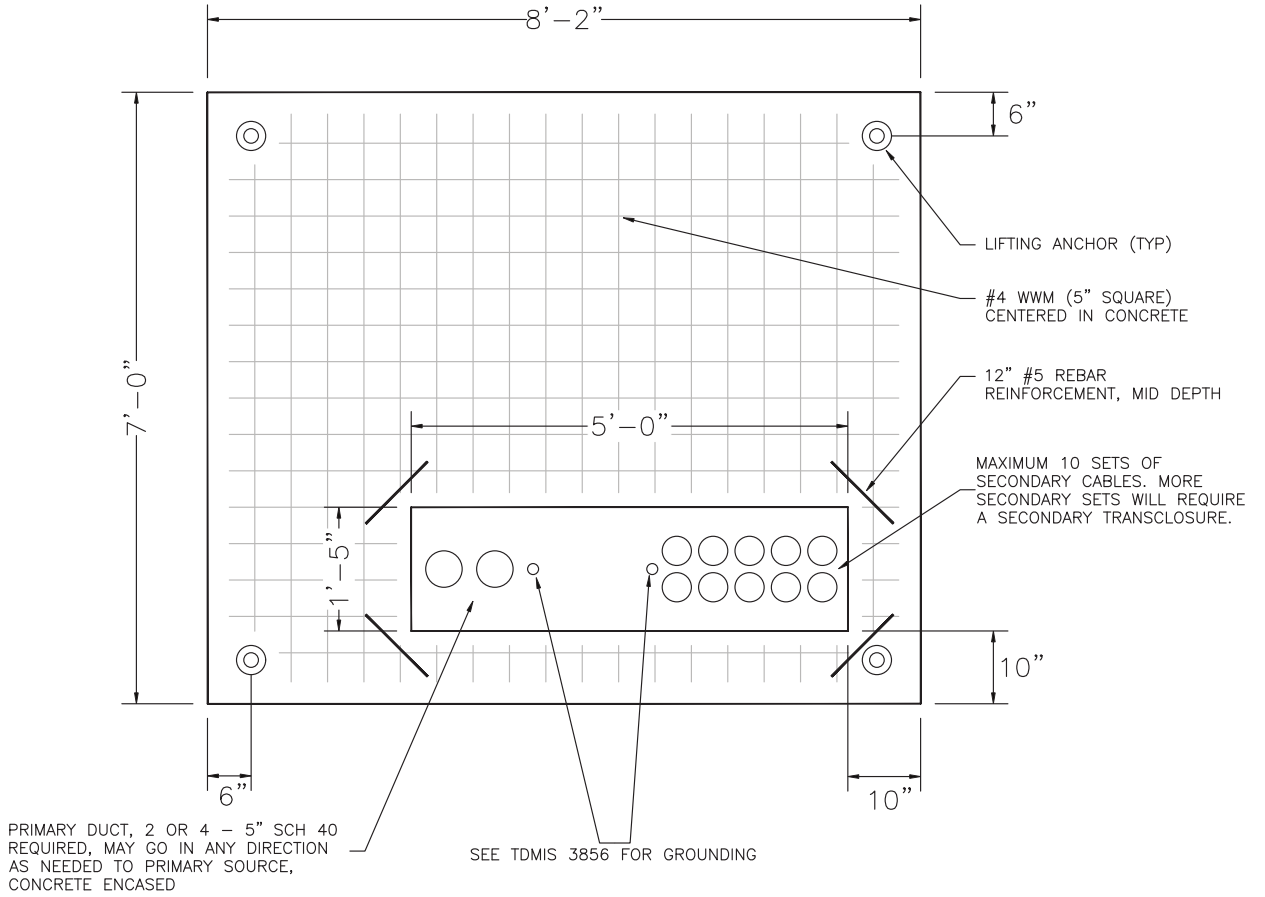

TDMIS 3800 – UNDERGROUND DEVELOPMENTS			
	<p>DIVISION OF POWER TRANSMISSION AND DISTRIBUTION MATERIAL AND INSTALLATION SPECIFICATIONS</p>	ISSUE	NUMBER
		12/19	3852

SECTION 3800 – UNDERGROUND DEVELOPMENTS

3853. BOLLARDS

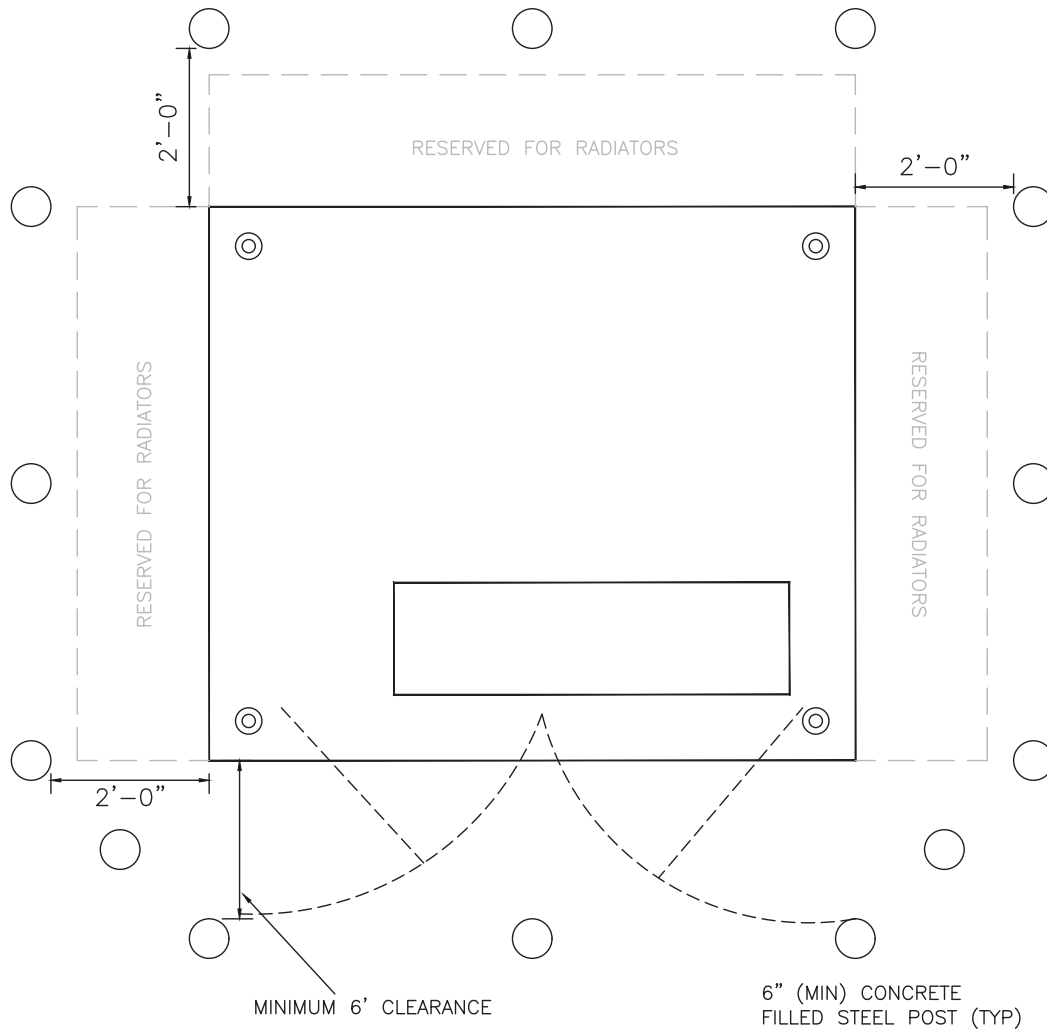

Notes:

1. 6 foot minimum clearance.
2. DOP Engineering shall designate the number and location of Bollards by marking the Bollards of this drawing as follows:

Bollards Required	●
Removable Bollard Required	⊘
Bollards Not Required	⊗

TDMIS 3800 – UNDERGROUND DEVELOPMENTS			
NUMBER	ISSUE	DIVISION OF POWER TRANSMISSION AND DISTRIBUTION MATERIAL AND INSTALLATION SPECIFICATIONS	 THE CITY OF COLUMBUS DEPARTMENT OF PUBLIC UTILITIES
3853	12/19		

3854. TYPICAL BOLLARD DETAIL

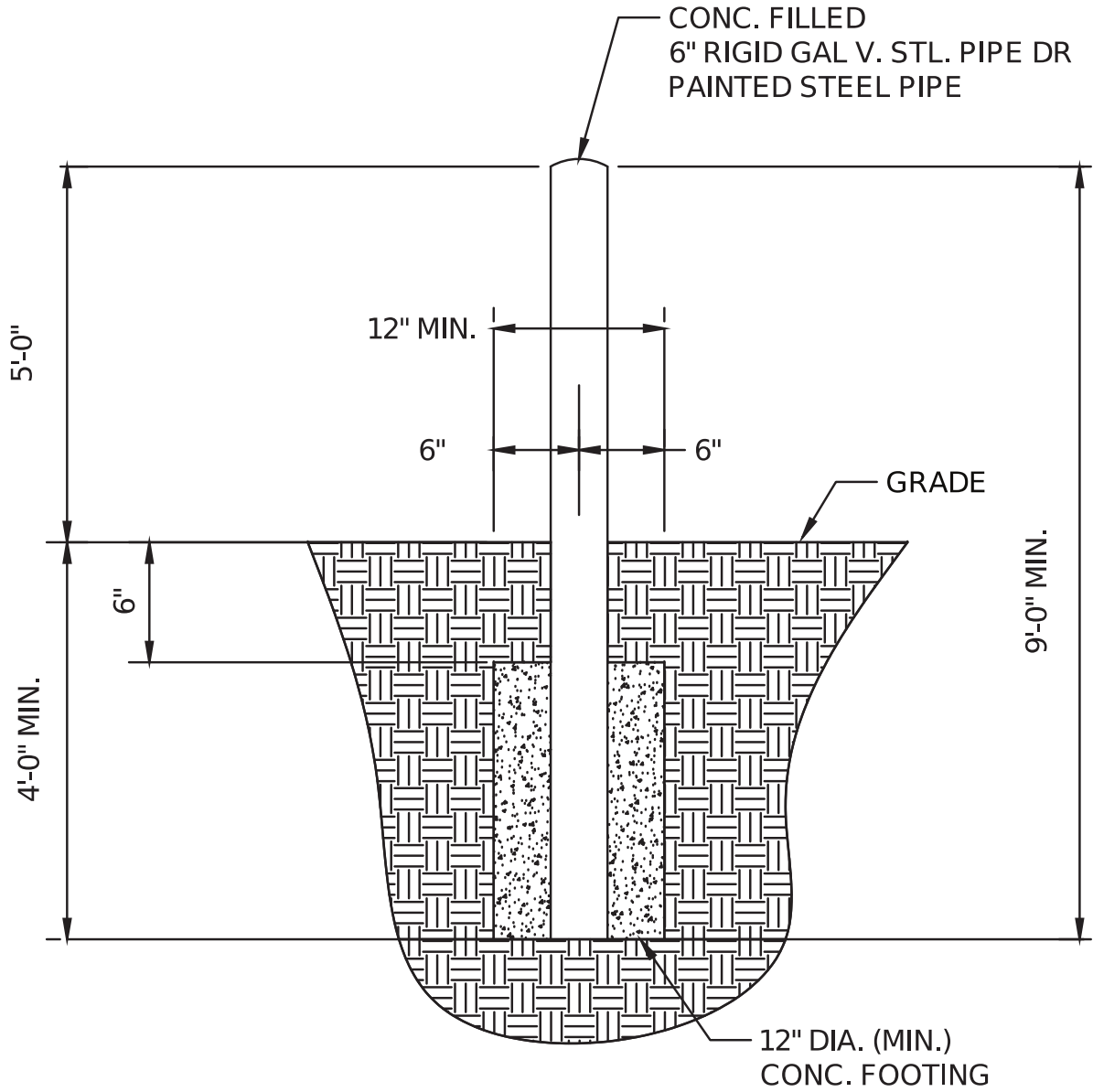

TDMIS 3800 – UNDERGROUND DEVELOPMENTS			
	DIVISION OF POWER TRANSMISSION AND DISTRIBUTION MATERIAL AND INSTALLATION SPECIFICATIONS	ISSUE	NUMBER
		12/19	3854

SECTION 3800 – UNDERGROUND DEVELOPMENTS

3855. OIL CONTAINMENT INSTALLATION DETAIL

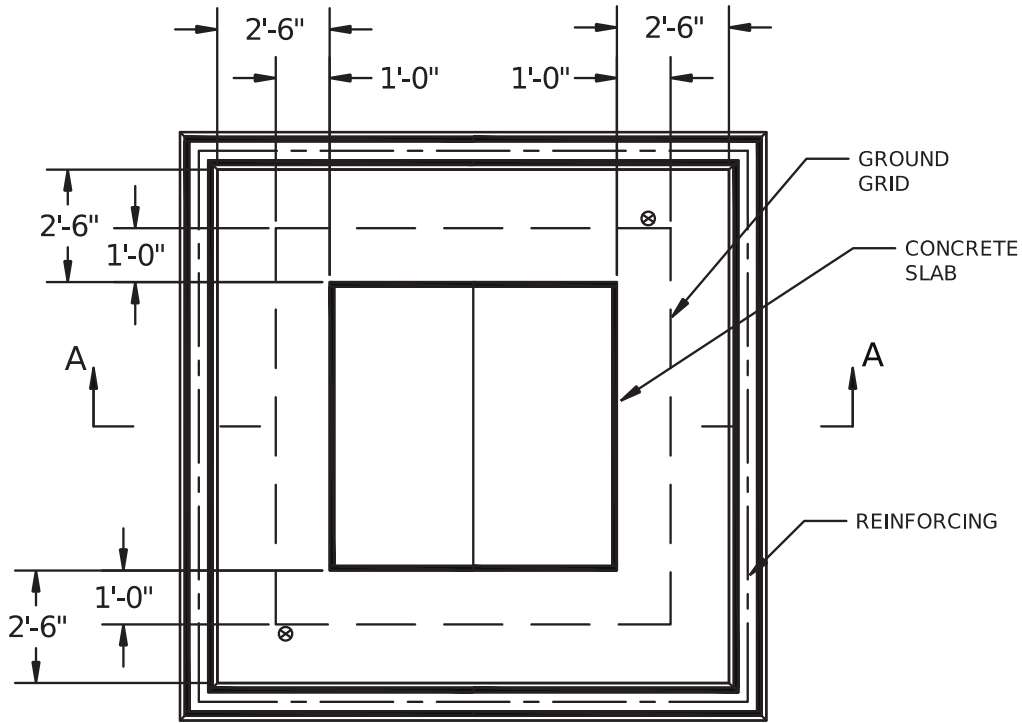

TYPICAL CROSS SECTION OF CONTAINMENT PAD A-A

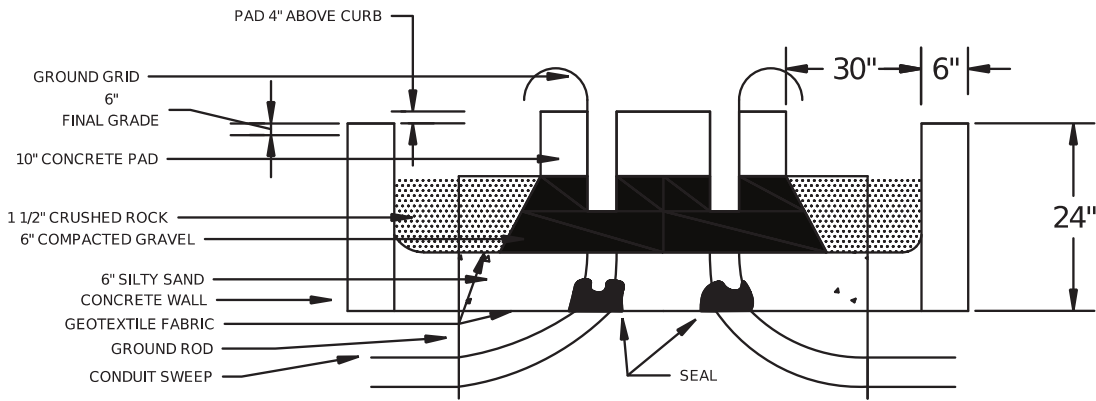



TDMIS 3800 – UNDERGROUND DEVELOPMENTS

NUMBER	ISSUE	DIVISION OF POWER TRANSMISSION AND DISTRIBUTION MATERIAL AND INSTALLATION SPECIFICATIONS	
3855	12/19		

SECTION 3800 – UNDERGROUND DEVELOPMENTS

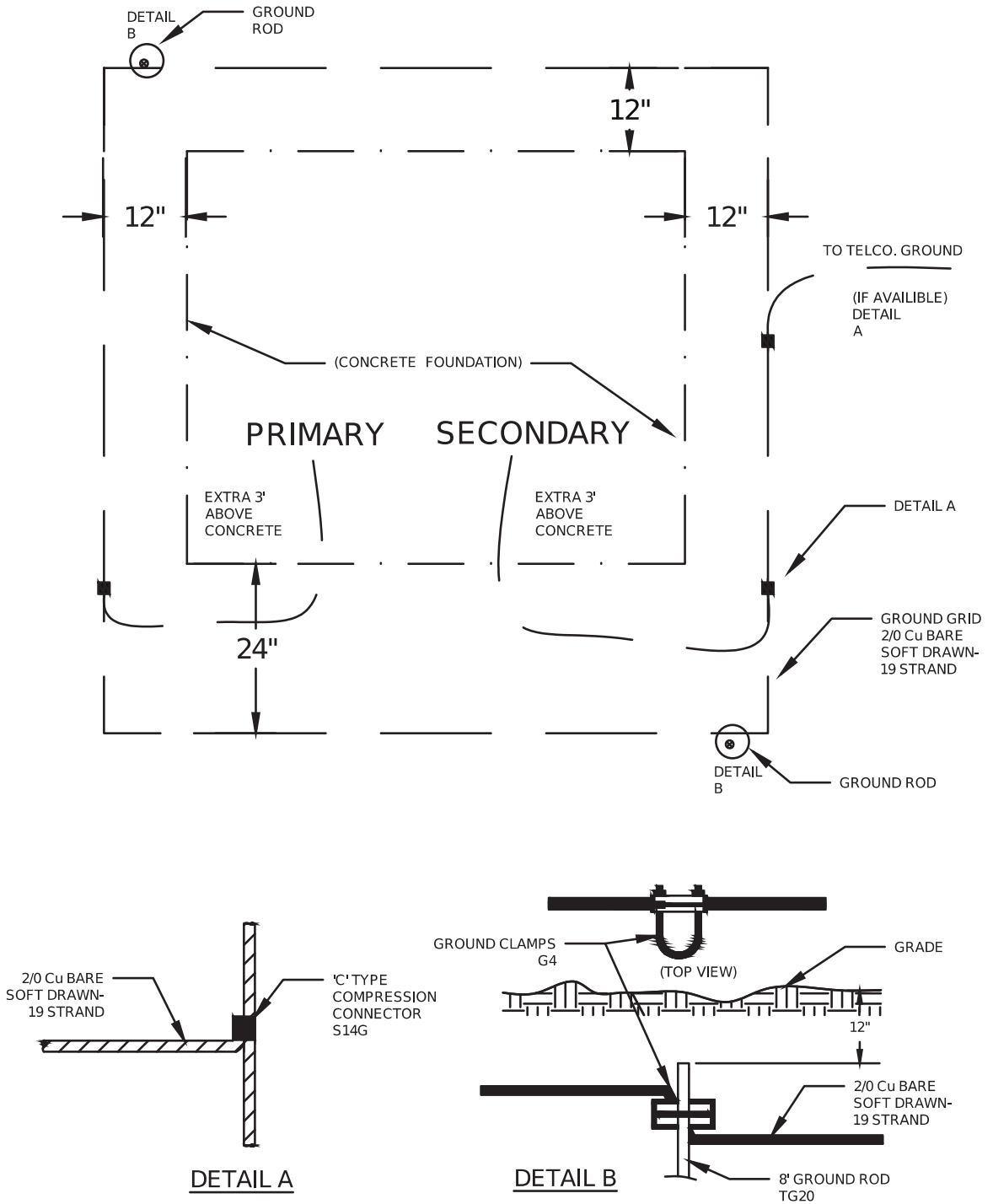
3856. GROUND GRID INSTALLATION DETAILS



TDMIS 3800 – UNDERGROUND DEVELOPMENTS			
	<p align="center">DIVISION OF POWER TRANSMISSION AND DISTRIBUTION MATERIAL AND INSTALLATION SPECIFICATIONS</p>	ISSUE	NUMBER
		12/19	3856

SECTION 3800 – UNDERGROUND DEVELOPMENTS

3857. LOOP FEED PAD-MOUNTED TRANSFORMER INSTALLATION

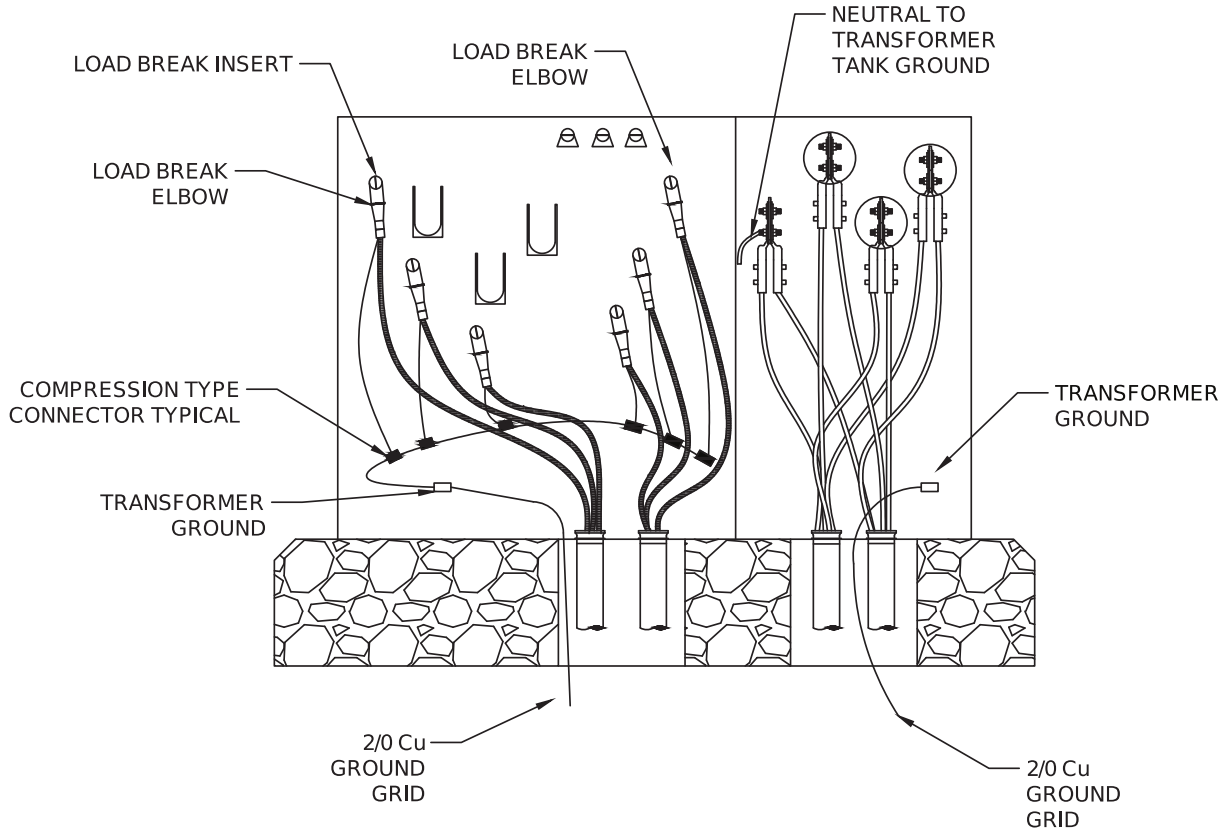

TDMIS 3800 – UNDERGROUND DEVELOPMENTS			
NUMBER	ISSUE	DIVISION OF POWER TRANSMISSION AND DISTRIBUTION MATERIAL AND INSTALLATION SPECIFICATIONS	
3857	12/19		

SECTION 3800 – UNDERGROUND DEVELOPMENTS

3858. LOOP FEED PAD-MOUNTED TRANSFORMER INSTALLATION WITH OPEN POINT

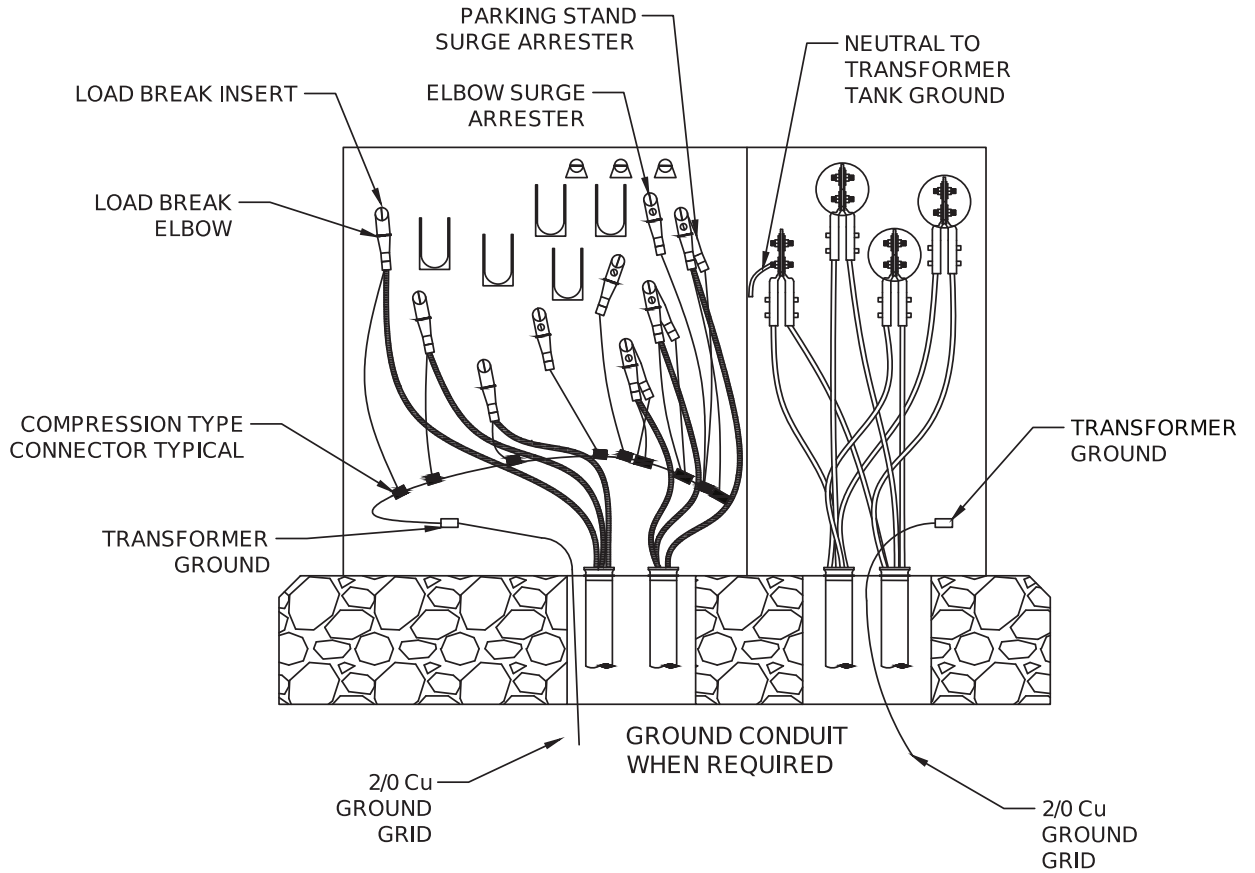

TDMIS 3800 – UNDERGROUND DEVELOPMENTS			
	DIVISION OF POWER TRANSMISSION AND DISTRIBUTION MATERIAL AND INSTALLATION SPECIFICATIONS	ISSUE	NUMBER
		12/19	3858

SECTION 3800 – UNDERGROUND DEVELOPMENTS

3859. LOOP FEED PAD-MOUNTED TRANSFORMER INSTALLATION WITH RADIAL FEED

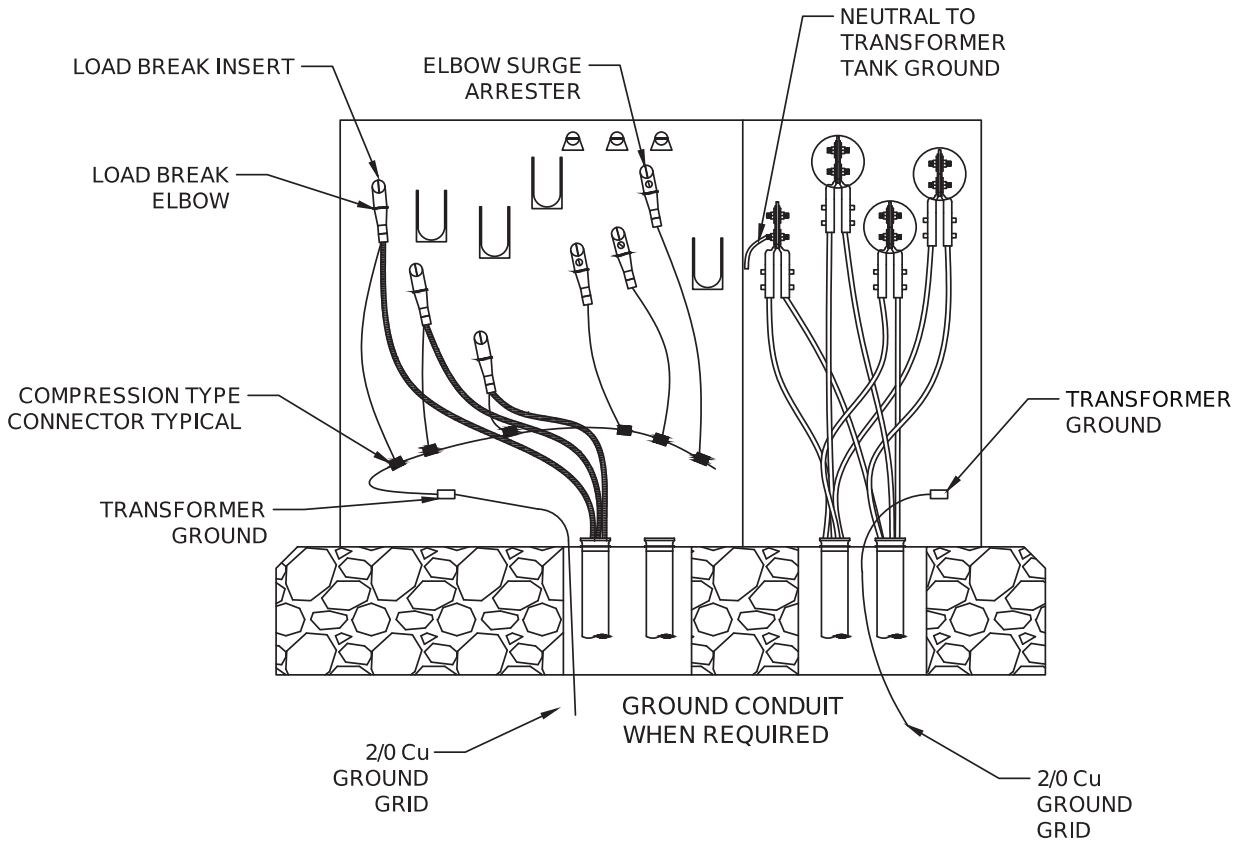

TDMIS 3800 – UNDERGROUND DEVELOPMENTS			
NUMBER	ISSUE	DIVISION OF POWER TRANSMISSION AND DISTRIBUTION MATERIAL AND INSTALLATION SPECIFICATIONS	
3859	12/19		