

FOUNDATION DETAILS				
PEDESTAL TYPE (HT.)	DEPTH (D)	BOLT CIRCLE	REBAR REQUIRED	ANCHOR BOLT (DIA.)
STD. DWG 4100 (5')	3'	14.5"	NO	1"
STD. DWG 4101 (10.7')	3'	14.5"	NO	1"
STD. DWG 4102 (12.7')	4'	14.5"	YES	1"
STD. DWG 2187 (15.1')	4'	14.5"	YES	1"
STD. DWG 4103 (17.5')	4'	14.5"	YES	1"
STD. DWG 4104 (21')	4'	14.5"	YES	1"
STD. DWG 4106 (10.7' DECORATIVE)	4'	9.5"	NO	1"

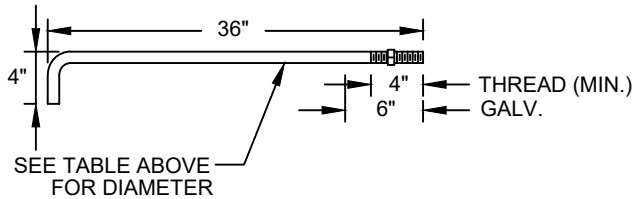
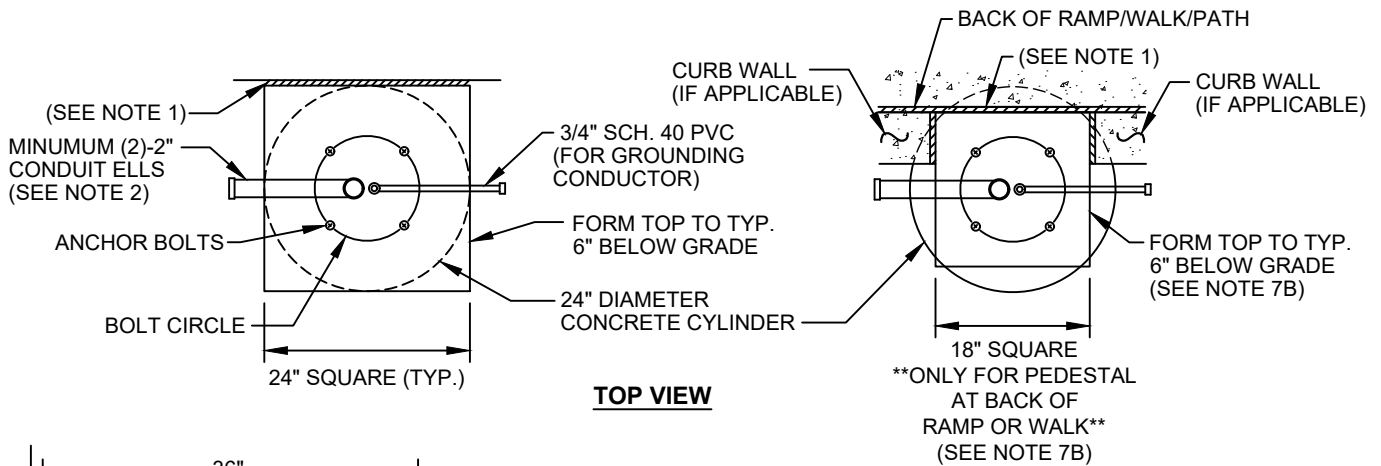
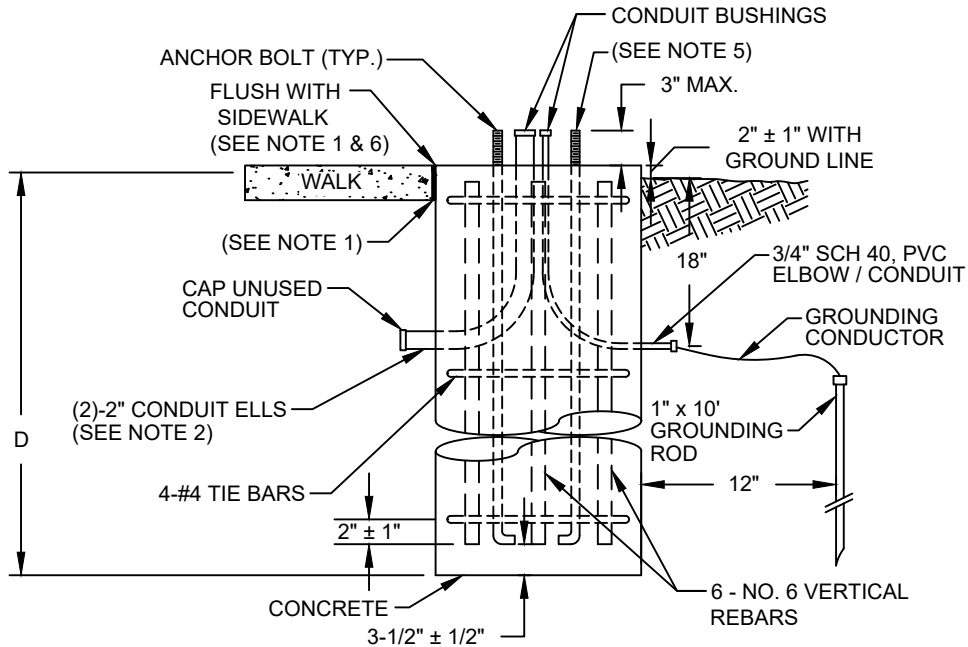

PEDESTAL ANCHOR BOLT
ANCHOR BOLT PROJECTS 2.75" ABOVE BASE

- (4) 36"-8 NC GALV STEEL ANCHOR BOLTS, ASTM F1554 GR55, TOP 10" GALV PER ASTM A153, "L" SHAPED (4"L)
- (4) 8 NC GALV STEEL HEX NUTS
- (4) GALV STEEL LOCKWASHERS

PEDESTAL FOUNDATION

CITY OF COLUMBUS, OHIO
DEPARTMENT OF PUBLIC SERVICE
DIVISION OF DESIGN AND CONSTRUCTION

STD DWG
4163

07/01/2021

CITY ENGINEER

SHT 1 OF 2

NOTES:

1. 1/2" PREFORMED JOINT FILLER AS PER 608.03C SHALL BE USED BETWEEN FOUNDATIONS AND ADJACENT PAVED OR CONCRETE AREAS.
2. THE TYPE, SIZE, NUMBER (MINIMUM OF 2) AND ORIENTATION OF CONDUIT ELLS SHALL BE AS SHOWN IN THE PLAN, EXCEPT THAT A 3/4" SCHEDULE 40 PVC CONDUIT SHALL BE INSTALLED IN EACH FOUNDATION. UNUSED CONDUIT ELLS SHALL BE CAPPED.
3. THE SIZE, NUMBER AND LOCATION OF ANCHOR BOLTS SHALL BE IN ACCORDANCE WITH THE MANUFACTURER'S RECOMMENDATIONS.
4. ALL PEDESTALS SHALL BE PROVIDED WITH A METHOD OF SECURELY ATTACHING A 4 AWG INSULATED COPPER GROUNDING CONDUCTOR TO THE PEDESTAL OR ANCHOR BOLT. NO CABLES OR CONNECTIONS SHALL BE EXTERNAL TO THE PEDESTAL.
5. THE PEDESTAL BASE SHALL SET ON THE FOUNDATION TOP WITHOUT GROUTING, PREFORMED FILLERS OR LEVELING NUTS UNDER THE BASE. STAINLESS STEEL SHIMS MAY BE USED UNDER THE BASE FOR LEVELING THE INSTALLATION.
6. THE FOUNDATION AREA OF CONTACT WITH THE PEDESTAL BASE SHALL BE LEVEL. IF ADJACENT PAVED AREAS SLOPE, THE REMAINDER OF THE FOUNDATION TOP SHALL BE BEVELED TO MEET THE ADJACENT ELEVATIONS.
7. THE TOP OF THE FOUNDATION SHALL BE SET BASED ON THE FOLLOWING GUIDELINES:

A. FOUNDATION LOCATED ENTIRELY IN WALK OR CONCRETE AREA

TOP OF FOUNDATION SHALL BE AS PER CITY OF COLUMBUS STANDARD DRAWING 4161.

B. FOUNDATION LOCATED AT BACK OF RAMP AND/OR BEHIND WALK OR PATH

THE FORMED TOP SHALL BE 18"X18" SQUARE (APPLIES TO 5' AND 10.7' TALL PEDESTALS ONLY). THE TOP OF FOUNDATION SHALL BE FLUSH WITH ADJACENT WALK OR CONCRETE AREA. WHERE CURB WALL IS UTILIZED AT THE BACK OF WALK, THE TOP OF THE FOUNDATION SHALL BE FLUSH WITH THE TOP OF THE CURB WALL. THE FACE OF FOUNDATION ADJACENT TO THE BACK OF THE WALK SHALL MATCH THE PROFILE OF ADJACENT CURB WALL.

C. FOUNDATION LOCATED ADJACENT TO WALK OR CONCRETE AREA

TOP OF FOUNDATION SHALL BE FLUSH WITH WALK OR CONCRETE AREA.

D. FOUNDATION LOCATED ADJACENT TO WALK OR CONCRETE WITH STEEP GRADE CHANGE

THE BACK SIDE OF THE FOUNDATION SHALL MATCH THE GROUND SLOPE AND THE STREET SIDE OF THE FOUNDATION SHALL BE ABOVE THE SIDEWALK OR CONCRETE AREA AND COMPLETELY OUT OF THE SIDEWALK OR CONCRETE AREA.

PEDESTAL FOUNDATION

CITY OF COLUMBUS, OHIO
DEPARTMENT OF PUBLIC SERVICE
DIVISION OF DESIGN AND CONSTRUCTION



CITY ENGINEER

STD DWG

4163

07/01/2021

SHT 2 OF 2