

**INSTALLATION WITH CONNECTION TO
ROADWAY UNDERDRAIN**

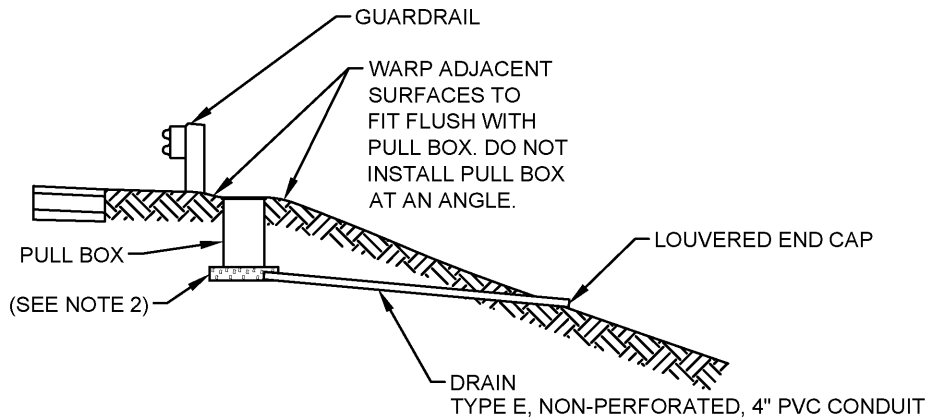

INSTALLATION WITH INDEPENDENT DRAIN

NOTES:

1. AFTER THE CONDUITS HAVE BEEN INSTALLED, ANY OPENING IN THE PULL BOX WALL SHALL BE COMPLETELY FILLED WITH MORTAR OR CONCRETE AND FINISHED FLUSH WITH THE INSIDE PULL BOX WALL. (NO VOIDS)
2. PULL BOX DRAINS IN ACCORDANCE WITH CMSC 603 SHALL BE INSTALLED WHEN SPECIFIED, OR AS DIRECTED BY THE ENGINEER.
3. CONTRACTOR TO VERIFY ROADWAY UNDERDRAIN IS BELOW THE PULL BOX AGGREGATE BEFORE INSTALLING DRAIN.

PULL BOX UNDERDRAIN DETAILS

CITY OF COLUMBUS, OHIO
DEPARTMENT OF PUBLIC SERVICE
DIVISION OF DESIGN AND CONSTRUCTION

Hassan Zahran

CITY ENGINEER

STD DWG
4020

5/01/2014

SHT 1 OF 1