

SIGN WIRE CLAMP

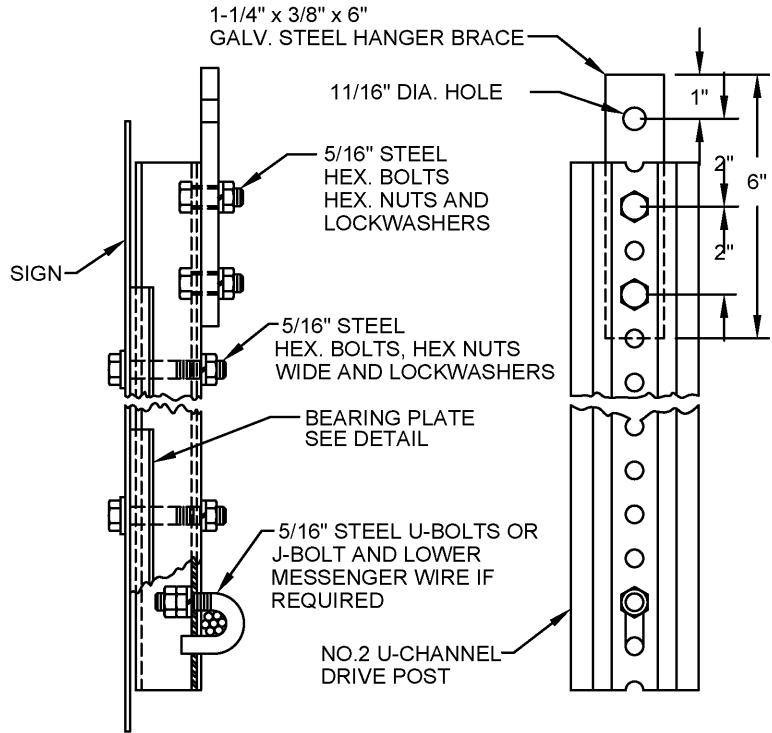

SINGLE SIGN HANGER ASSEMBLY

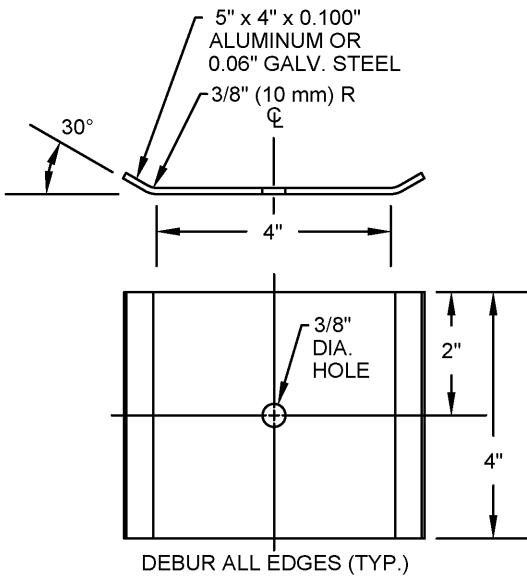

BEARING PLATE

TYPE 1

**SIGN HANGER ASSEMBLY
SPAN WIRE**

CITY OF COLUMBUS, OHIO
DEPARTMENT OF PUBLIC SERVICE
DIVISION OF DESIGN AND CONSTRUCTION

STD DWG
4250

Masoud Zahran

5/01/2014

CITY ENGINEER

SHT 1 OF 2

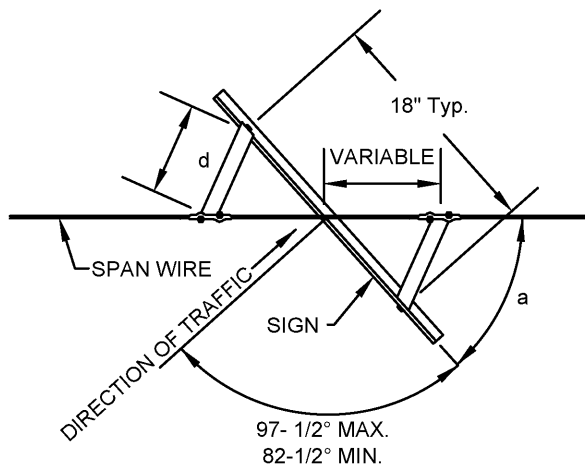

a	d (in)
0°	0
15°	2.4
30°	4.7
45°	6.9
60°	9

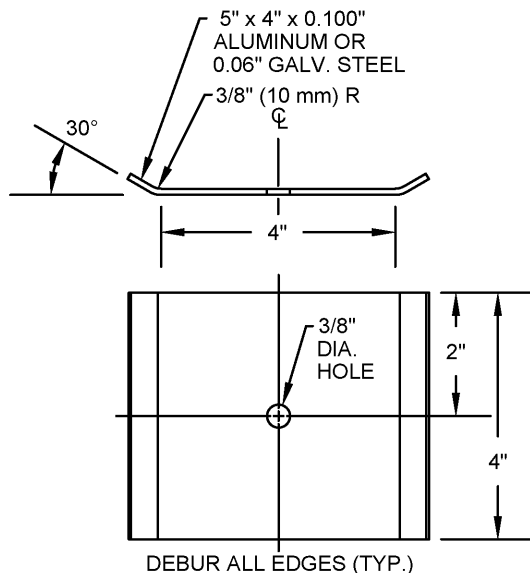
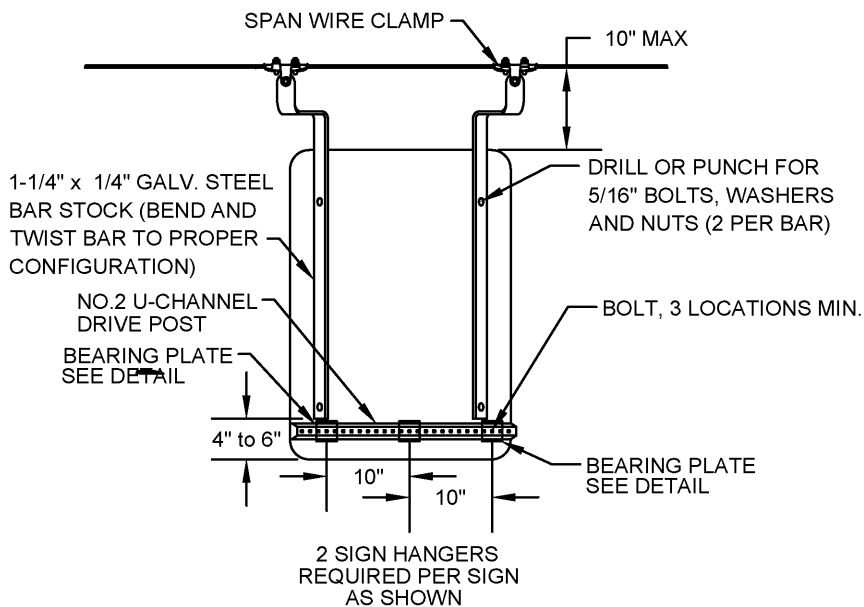

BEARING PLATE

TYPE 2

SIGN HANGER ASSEMBLY SPAN WIRE

CITY OF COLUMBUS, OHIO
DEPARTMENT OF PUBLIC SERVICE
DIVISION OF DESIGN AND CONSTRUCTION

STD DWG
4250

Hassan Zahran

5/01/2014

CITY ENGINEER

SHT 2 OF 2