

DESIGN MEMO 9.04

To: Designers, Contractors, and City Departments
Date: January 1, 2025
Subject: Turning Radii
Category: Traffic

Table of Contents

1	Purpose.....	2
2	Applicability	2
3	Definitions	3
4	Design Guidance	4
4.1	Design Vehicle	4
4.1.1	Default Design Vehicle	4
4.1.2	Selecting an Alternative Design Vehicle	7
4.1.3	Minimum Turning Radii of Vehicles.....	7
4.1.4	Check Vehicle	8
4.1.5	Turning Vehicle Design Speed.....	8
4.2	Relationship Between Effective and Actual Radius	8
4.2.1	Intersection Skew	8
4.2.2	Determining the Actual Radius by Evaluating the Effective Radius.....	11
4.2.3	Curbside Use Considerations	11
4.2.4	Design Vehicle RE and RA Tables for Various Curbside Conditions	13
4.2.5	Truck Aprons	14
4.3	Other Design Considerations	15
5	Encroachment Policy	15
5.1	Most Common Vehicle	16
5.2	Design Vehicle	16
5.2.1	Local Street to Local Street.....	16
5.2.2	Stop-Controlled Minor Leg, Uncontrolled Major Leg.....	16



5.2.3 Signalized Intersections 17
5.3 Check Vehicle 17

1 Purpose

Intersection design must balance the needs of all users of the street including motorists, transit vehicles, freight vehicles, emergency services, pedestrians, and bicyclists.

A corner with a larger radius can improve a motorist’s ability to turn into the nearest receiving lane and avoid encroaching into adjacent travel lanes when completing the turn. A larger radius can also reduce the likelihood that a larger vehicle will track over the curb or adjacent sidewalk; however, a large radius allows smaller vehicles to turn at higher speeds, decreasing motorist yielding to pedestrians and bicyclists and increasing the distance pedestrians need to cross.

A corner with a small radius requires motorists to turn slower. This can reduce the rates and severity of collisions involving turning vehicles and vulnerable users by encouraging motorists to make slower right turns as well as improve yielding to other street users who have the right of way. The use of smaller corner radii can also simplify curb ramp design, facilitate the installation of directional curb ramps, and provide additional space for pedestrians waiting to cross the street. Smaller curb radii are especially beneficial at intersections with pedestrian and bicyclist activity and intersections where crashes result from motorist failure to yield due to higher right-turning speeds. Smaller corner radii can also shorten the crossing distance (reducing exposure) for pedestrians and can increase the visibility of pedestrians and bicyclists to approaching motorists, especially where curb extensions are used.

2 Applicability

Until further notice, this direction will be used for scoping, design, and construction of projects within the City of Columbus right-of-way.

The geometric design of the corner radii will vary based on the street classification, proposed street enhancements, the transportation context, and the type of vehicles that are expected to frequently use the roadway.

Evaluation of intersection turning radii should be completed during the beginning stage of the design process, preferably during preliminary alignment. The evaluation of intersection turning radii shall be performed following the process outlined in this memo.



3 Definitions

Definitions of key terms in this memo are provided below. Additional definitions that may be relevant to other design memos are provided in City of Columbus Design Memo 1.00: Introduction.

Actual Radius, RA: The radius defined by the curb line at an intersection. A portion of the actual radius may be mountable if it is designed to be a truck apron (see Section 4.2.5).

Check Vehicle: An infrequent user at a given intersection, usually a larger, less maneuverable vehicle, which should be considered in conjunction with the Encroachment Policy.

Corner Radius: The radius of the curb or edge of pavement connecting two roadways at intersections. It is also referred to as a radius return, curb return, curb return radius, or curb radius.

Design Vehicle: The largest frequent vehicle classification used at a given intersection. The Design Vehicle is used to help determine the effective turning radius that is necessary.

Effective Radius, RE: The minimum radius appropriate for turning from the right-hand travel lane on the approach street to the appropriate lane of the receiving street, accounting for the presence of parking, bike lanes, curb extensions, or other features. The effective radius is usually equal to the minimum inside turning radius of the design vehicle. Full height curb should be outside of the effective radius for pedestrians waiting on the sidewalk.

Local Street: See Design Memo 3.01 for further information on street classifications.

Minimum Inside Turning Radius: The minimum radius necessary to accommodate the smallest circular path of the inside wheel of the turning vehicle.

Most Common Vehicle: In almost all locations, the most common vehicle negotiating turns is a passenger vehicle.

Neighborhood Traffic Circle: Raised islands in residential intersections intended to reduce motor vehicle speeds.

Non-Local Street: See Design Memo 3.01 for further information on street classifications.

Oversteer: Making a wide turn with the front wheels at an intersection to ensure the rear wheels do not track over the curb while turning. Oversteering may allow larger vehicles to maneuver around corners at a tighter radius than otherwise possible.

Skewed Intersection: An intersection where two streets intersect at an angle less than 75 degrees (an acute angle) or greater than 105 degrees (an obtuse angle).

Standard Intersection: An intersection where two streets intersect at an angle between 75 degrees and 105 degrees with 90 degrees being the preferred angle.

Swept Path: The envelope encompassing the entire vehicle body, including any part of the vehicle structure which may overhang the wheelbase (i.e. mirrors), during a turn.

Transit Street: See Design Memo 3.01 for further information on street classifications.



4 Design Guidance

4.1 Design Vehicle

The effective turning radii of all vehicles which may use an intersection need to be considered during design to avoid tracking over curb, tree lawn, or sidewalk. A design vehicle should be the largest frequent user at a given intersection, which is used to determine the required intersection effective corner radii. The street functional classification and context is used to identify the preliminary design vehicle for the conditions.

4.1.1 Default Design Vehicle

The default design vehicle is a 30-foot long, single-unit truck (SU-30). There are several exceptions to the default design vehicle identified in **Table 1**, which are based on the functional classification and context of the intersecting streets. The corresponding effective turning radius accommodates a right turn based upon the minimum inside turning radius (see **Table 2**) required for the design vehicle.

Table 1: Design Vehicle Exceptions to the Default SU-30 Design Vehicle

Street A	Street B	Design Vehicle	Corresponding Turning (Effective) Radius
Local Streets	Local Streets	DL-27	16 feet
All Non-Local Streets	Local Streets	DL-27	16 feet
Transit Streets ¹	Transit Streets ¹	CITY-BUS	25 feet
100' or Greater Suburban ROWs per MMTP	100' or Greater Suburban ROWs per MMTP	Context Specific ⁴	Context Specific ⁴
Truck Route ⁵	Truck Route ⁵	Context Specific ²	Context Specific ²
Streets with neighborhood traffic circles	Streets with neighborhood traffic circles	SU-30 ³	30 feet

¹ Transit Streets are defined in Design Memo 3.01

² Designers should provide supporting documentation to the City, including detailed AutoTURN or equivalent turning analysis, to support evaluation for specific corner design. In these situations, the appropriate design vehicle will be established as part of the design scoping process.

³ The DL-27 may be an acceptable design vehicle for some residential intersections if the frequency of the SU-30 will be minimal.

⁴ Intersections of two roadway segments defined by the Columbus Multi-Modal Thoroughfare Plan (MMTP) as 100 – Suburban Community Connector, 120 – Suburban Commuter Corridor, 160 – Suburban Commuter Corridor will be designed to meet the turning radius of a WB-50 vehicle unless otherwise specified in the scope.

⁵ Truck routes are defined in Columbus Design Memo 3.01, Section 4.4

Refuse collection trucks and fire trucks may be identified as the design vehicle or check vehicle for specific corridors or intersections. Field testing performed by City of Columbus staff has determined the characteristics of these vehicles are similar to that of an SU-30. The designer should compare these vehicles to the default design vehicle or the design vehicle exceptions (**Table 1**) to ensure they are accommodated in accordance with the Encroachment Policy (see Section 5).



For the purposes of geometric design, it is important to note that each design vehicle has larger physical dimensions and a larger minimum turning radius than most vehicles in its class as shown in **Figure 1**. Therefore, the design vehicle dimensions represent maximum values.

Figure 2 provides a vehicle turning template for the DL-27.

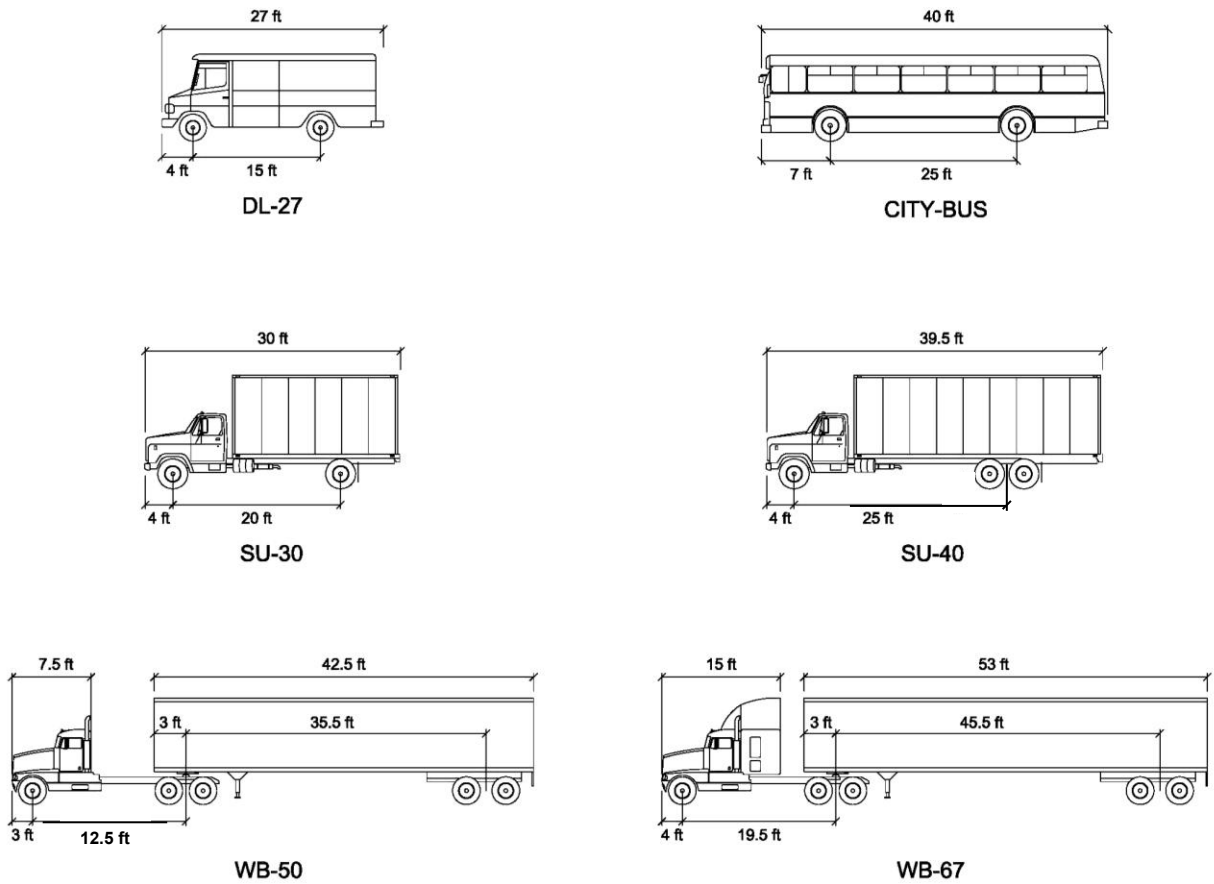
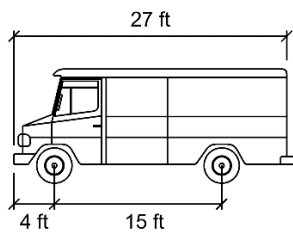
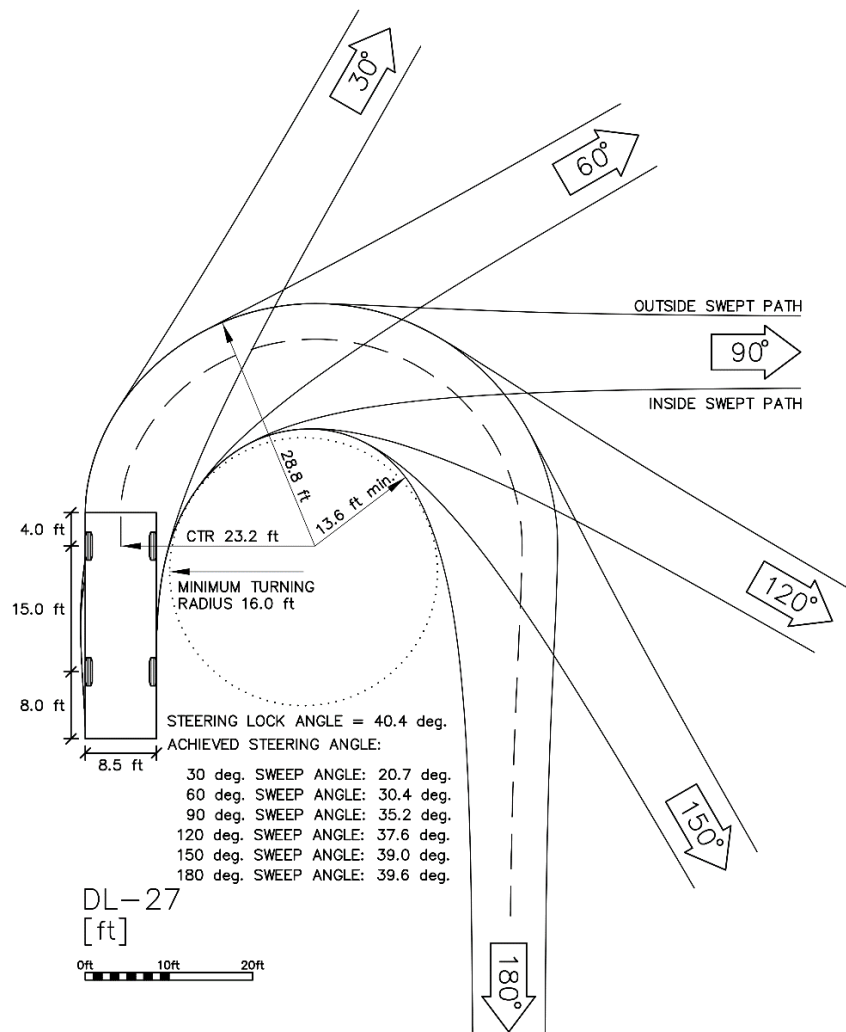

Figure 1: Common Design Vehicle Profiles from AASHTO "Green Book" (2018)





DL-27

	feet
Width	: 8.50
Track	: 8.50
Lock to Lock Time	: 6.0
Steering Angle	: 40.4

Figure 2: DL-27 Turning Vehicle Template Based on Field Measurements



4.1.2 Selecting an Alternative Design Vehicle

When local context, future development, or empirical data informs the selection of a design vehicle that is not listed in **Table 1** or **Figure 1**, the design vehicle shall be established as part of the approved design scope for the project. Supporting AutoTURN or equivalent turning analysis will be required to identify the minimum turning radius, effective radius, and the swept path of the alternative design vehicle.

4.1.3 Minimum Turning Radii of Vehicles

Table 2 shows the minimum outside turning radius (left wheel) and minimum inside turning radius (right wheel) required to allow vehicles to turn right at speeds less than 10 mph without the use of oversteering for a wide range of vehicles that operate on City of Columbus streets. The minimum inside turning radius will be equal to the effective turning radius required at locations where vehicles are expected to turn from a curbside lane into a curbside lane. At these locations the minimum inside turning radii will equal the minimum actual radius required. See **Figure 3**.

Table 2: Minimum Turning Radii for Common Vehicles

	Passenger Car ¹	Small delivery truck ²	Non-articulated COTA bus ¹	Single-Unit Truck ^{1,5}	Single-Unit Truck ¹	Interstate Semitrailer ^{1, 3}	Interstate Semitrailer ¹
	P	DL-27	CITY-BUS	SU-30	SU-40	WB-40 or WB-50	WB-67
Minimum outside radius (ft)	23.8	29.0	41.6	41.8	51.2	40	44.8
Minimum inside radius (ft)	14.4	16.0	24.5	28.4	36.4	19.3 ⁴	1.9 ⁴

¹ Based on AASHTO "Green Book" (2018)

² Based on NACTO and NJDOT DL-23 vehicles, modified based on field measurements of actual delivery vehicles

³ The WB-50 has the same performance characteristics as the WB-40 based upon review of AASHTO "Green Book" (2004)

⁴ WB-50s and WB-67s will require significant off-tracking if designed to this minimum radius, therefore a vehicle swept path analysis is required for each intersection where one of these trucks will be the design vehicle

⁵ SU-30 has been field tested by City of Columbus staff and encompasses multiple vehicles used to include refuse, school buses, fire trucks, delivery trucks, and street maintenance.

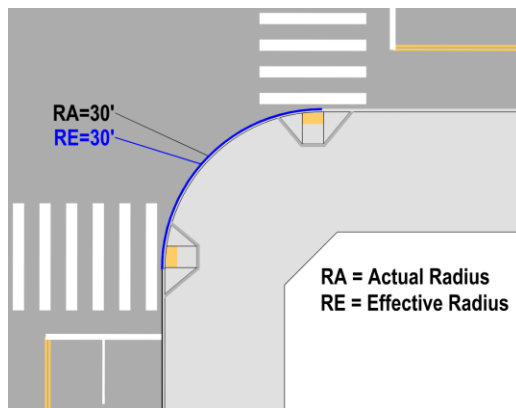

Figure 3: Example where Actual Radius is the Effective Radius



4.1.4 Check Vehicle

A check vehicle is any vehicle larger than the design vehicle (e.g., moving or loading truck) that may occasionally operate in the intersection. The check vehicle will vary based on street functional classification and the local context. The check vehicle is by default anticipated to encroach into adjacent and oncoming travel lanes to negotiate turns at intersections.

The check vehicle is discussed further in the Encroachment Policy (see Section 5). The designer may need to evaluate the use of a truck apron (see Section 4.2.5) to accommodate the turning needs of larger vehicles.

Emergency vehicles (e.g., police, fire, public utility, or ambulatory services) are exempt from traffic operating rules when responding to an emergency call and thus should be checked that they are always accommodated while having the option to use all available roadway space.

4.1.5 Turning Vehicle Design Speed

Intersections should be designed to encourage a 10-mph turning speed for passenger cars and a 5-mph turning speed for larger vehicles to promote yielding to pedestrians and bicyclists within intersections. These turning vehicle design speeds should be used for the vehicle swept path analysis which is used to determine required effective and actual turning radius values.

4.2 Relationship Between Effective and Actual Radius

The selected functional classification and design vehicle do not mandate the use of the effective radius to establish a minimum corner radius. In many instances smaller actual corner radii may be used depending upon the influence of the following factors which should be considered when selecting the final corner radius design parameters:

- Intersection skew
- Number of vehicle lanes
- Presence of bicycle lanes
- Presence of a permanent curb use (e.g., parking, loading, or bus stop)

4.2.1 Intersection Skew

Intersection skew, which is the angle at which two streets intersect, can have a significant impact on the design of a corner radius (see **Figure 4**) and impacts pedestrian and bicycle crossings by lengthening the crossing distance.



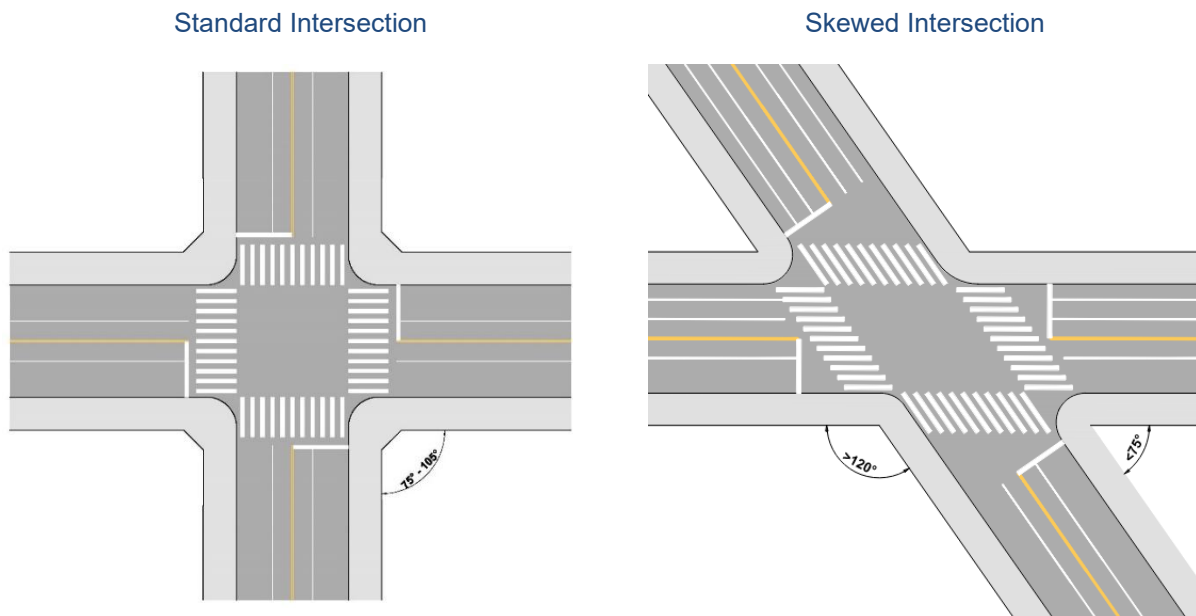

Figure 4: Intersection Skew Impact to Intersection Geometry

4.2.1.1 Standard Intersections

Intersections are classified as standard when the angle between intersecting approaches is between 75 and 105 degrees. Standard intersections are preferred over skewed intersections to minimize the size of the intersection and to maximize the sight lines between users. For intersections that intersect at 90 degrees, the corner effective and actual radius design must accommodate the minimum inside radius shown in **Table 2**.

4.2.1.2 Skewed Intersections - Acute Angle Quadrant

The use of **Table 2** is not appropriate for skewed intersections. A swept path analysis shall be necessary to identify the minimum turning radius and effective radius at skewed intersections.

Within a skewed intersection there are two quadrants that will result in an acute angle. A right turn within these quadrants presents unique challenges for larger vehicles. The increased length of the corner increases the degree of off-tracking for larger vehicles, which necessitates:

- Greater encroachment into adjacent lanes,
- Wider outside lanes to accommodate the turn, and/or
- A larger corner radius.

To minimize the intersection size, it may be desirable to provide a channelized right-turn lane to accommodate larger vehicles at skewed intersections. A channelized right-turn lane may be preferable to a larger corner radius to decrease the street crossing distance for pedestrians and bicyclists.

Where channelized right-turn lanes are provided, it will be necessary to choose between a flat angle (> 140 degrees) or a right-angle (< 120 degrees) approach to the cross street (**Figure 5**). To ensure the



channelized right-turn lane promotes motorists yielding at pedestrian and bicycle crossings, as well as to cross street motorists, a right-angle entry design is preferred. This design encourages lower turning speeds and improves the driver's view of people approaching crosswalks and motorists approaching from the cross street.

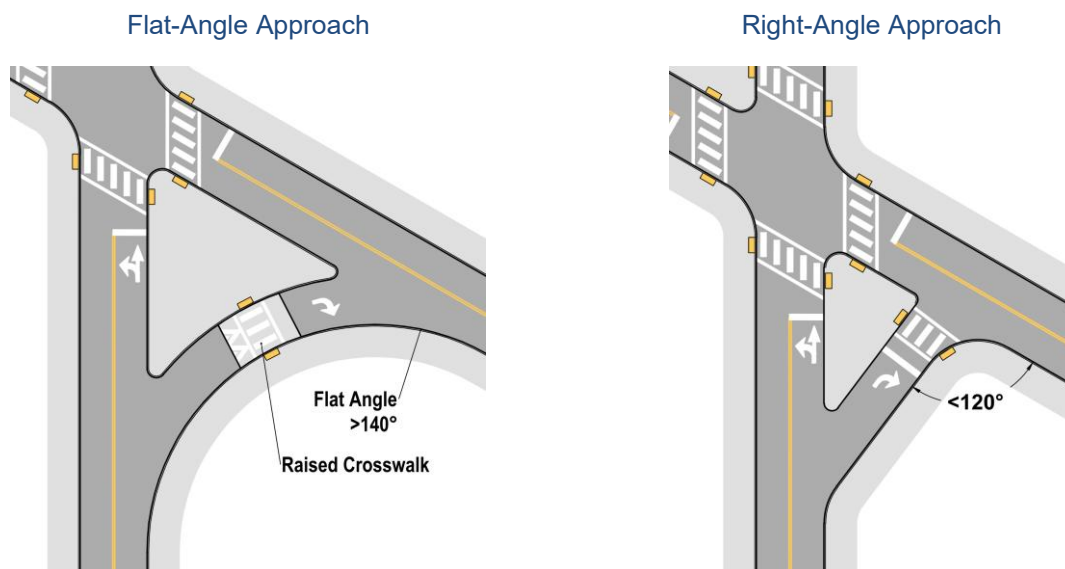

Figure 5: Channelized Right-Turn Design Options

The use of flat-angle approaches should be limited to locations where:

- Motorists have their own receiving lane on the cross street;
- Higher turning speeds are necessary for safe merging onto the cross street; and
- Pedestrian and bicycle crossings are not allowed or infrequent, or traffic control devices are provided to facilitate pedestrian and bicyclist crossings.

A raised crosswalk should be considered at channelized right-turn lanes where motorists do not face stop or traffic signal control to encourage motorist yielding. They may also be beneficial at yield, stop, and traffic signal-controlled intersections where it is desirable to reduce encroachments into the crosswalk. The crosswalk should be located to allow one vehicle to wait between the crosswalk and the cross street.

4.2.1.3 Skewed Intersection - Obtuse Angle Quadrant

Within a skewed intersection there are two quadrants that will result in an obtuse angle. A right turn within these quadrants presents fewer challenges to accommodating larger vehicles, but they also allow all vehicles to turn at higher speeds. It is preferred to reconfigure obtuse angle quadrants to an un-skewed configuration where possible. In some cases, this can be accomplished with a curb extension (see City of Columbus Design Memo 6.04: Curb Extensions). In most cases, there will be insufficient space to allow for a channelizing island to be constructed.

At unsignalized locations where right-turning traffic presents safety problems to pedestrians in the crosswalk, a raised crosswalk may be desirable to encourage motorist yielding. At signalized intersections



where motorists are not yielding due to higher operating speeds, it may be necessary to consider a protected right-turn phase.

4.2.2 Determining the Actual Radius by Evaluating the Effective Radius

Once the design vehicle has been selected based on the street functional class and any context-sensitive requirements (see Section 4.1) and the allowed encroachment has been determined (see Section 5), the actual curb radius can be determined. The smallest actual curb radius should be chosen to accommodate the required effective radius of the design vehicle while considering allowed encroachment. The smallest actual radius shall be 5 feet for the intersection of two streets or a street with a driveway or alley.

The design vehicle is used to determine the effective radius (RE) that needs to be accommodated at an intersection corner. In some cases, the actual radius (RA) will be the same as the RE; this is limited to locations where vehicles turn from the curbside lane on the approach street into the curbside lane on the cross street and where no bicycle lanes or full-time curb use is present. In all other cases, the RE and the RA can be different.

Table 3, **Table 4**, and **Table 5** in Section 4.2.4 provide approximate values for the RE for various conditions; however, if necessary, the RE should be labeled on an exhibit provided to verify the actual values.

4.2.3 Curbside Use Considerations

The presence of bicycle lanes or full-time curb use provides the ability to minimize the RA. Where parking is allowed along a curbed street and curb extensions are not provided, most vehicles (except for WB-67 and larger vehicles) are able to turn without encroachment into adjacent lanes even where curb radii are relatively small. This is possible because the vehicles are turning from a position horizontally separated from the curb which results in a relatively large RE being available for the vehicles.

As illustrated in **Figure 6**, a standard intersection with parking on both intersecting streets and an actual radius of 15 feet has an RE of approximately 42 feet where vehicles turn into the near side curb lane. The RE is closer to 60 feet if they turn into the travel lane adjacent to the centerline. The RA could be reduced to 5 feet in this scenario while still providing a 30-foot RE to accommodate the default design vehicle (SU-30) turning into the curb lane.

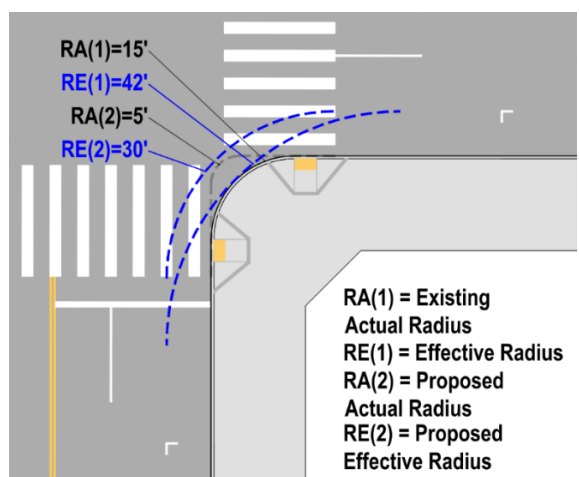

Figure 6: Example Effective and Actual Radius



Since the presence of full-time curb use has such an impact on the ability to reduce the RA, an important consideration is the decision to install a right-turn only lane, which requires a motorist to turn from the edge of the street. Where vehicles must make a right-turn from the edge of one travel lane to the near edge of the receiving travel lane, the corner radius will need to be based on the minimum turning radius of the selected design vehicle (**Table 2**). See **Figure 7**.

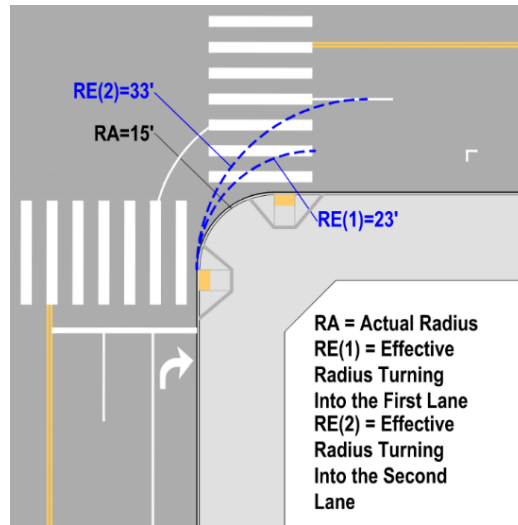

Figure 7: Example RE and RA with a Right-Turn Lane and No Parking on Approach Leg

Locations which have unrestricted (by time of day) parking and bike lanes present the opportunity to reduce the effective radius using curb extensions as shown in **Figure 8**. See City of Columbus Design Memo 6.04: Curb Extensions.

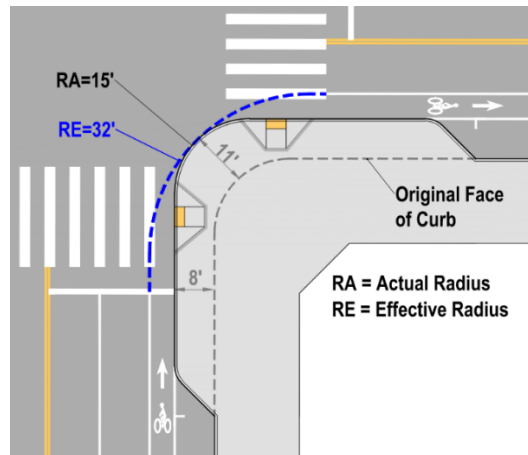

Figure 8: Example of Curb Extensions on Two Streets to Reduce the RE



4.2.4 Design Vehicle RE and RA Tables for Various Curbside Conditions

The following tables summarize how the relationship between the RE and the RA changes when considering the presence of bicycle lanes and/or full-time curb use on one or both intersecting streets. These tables assume standard intersections with 8-foot-wide parking lanes and 5-foot-wide bike lanes. **Table 3** and **Table 4** do not account for the possibility of encroaching into an adjacent lane. The RA may be smaller than the values identified in these tables if encroachment is allowable (see Section 5).

The locations identified with light green shading in **Table 3**, **Table 4**, and **Table 5** have the greatest difference between the RA and the RE. These are locations where a curb extension would be more effective at increasing pedestrian visibility and decreasing crossings distances than a small corner radius alone. See City of Columbus Design Memo 6.04: Curb Extensions.

The locations identified with light blue shading have the least difference between the RA and the RE, where either bicycle lanes or full-time curb use (or both) are not present on one or both of the intersecting streets. These are locations where a truck apron (see Section 4.2.5) may be considered to slow the turning speed of the most common vehicle.

At skewed intersections, the goal is to develop a design that removes or reduces the skew to minimize the size of the intersection. A swept path analysis may be necessary to determine the appropriate corner design.

Table 3: Relationship Between RA and RE for the Default Design Vehicle (SU-30)

			Street A				
			Parking	No	No	Yes	Yes
			Bike Lane	No	Yes	No	Yes
Street B	Parking	Bike Lane					
	No	No		RA = 30' (RE ≈ 30')	RA = 25' (RE ≈ 30')	RA = 25' (RE ≈ 30')	RA < 10' (RE ≈ 30')
	No	Yes		RA = 25' (RE ≈ 30')	RA = 15' (RE ≈ 30')	RA < 10' (RE ≈ 30')	RA = 5' (RE ≈ 30')
	Yes	No		RA = 25' (RE ≈ 30')	RA < 10' (RE ≈ 30')	RA = 5' (RE ≈ 30')	RA = 5' (RE ≈ 35')
	Yes	Yes		RA < 10' (RE ≈ 30')	RA = 5' (RE ≈ 30')	RA = 5' (RE ≈ 35')	RA = 5' (RE ≈ 45')

Note: RA is the actual corner radius; RE is the effective radius. Table values do not account for the possibility of encroaching into the adjacent lane (see Section 5).

Table 4: Relationship Between RA and RE for DL-27

			Street A				
			Parking	No	No	Yes	Yes
			Bike Lane	No	Yes	No	Yes
Street B	Parking	Bike Lane					
	No	No		RA = 30' (RE ≈ 30')	RA = 15' (RE ≈ 20')	RA = 10' (RE ≈ 20')	RA = 5' (RE ≈ 20')
	No	Yes		RA = 30' (RE ≈ 35')	RA = 5' (RE ≈ 20')	RA = 5' (RE ≈ 25')	RA = 5' (RE ≈ 30')
	Yes	No		RA = 25' (RE ≈ 35')	RA = 5' (RE ≈ 25')	RA = 5' (RE ≈ 30')	RA = 5' (RE ≈ 40')
	Yes	Yes		RA = 20' (RE ≈ 30')	RA = 5' (RE ≈ 35')	RA = 5' (RE ≈ 40')	RA = 5' (RE ≈ 45')

Note: RA is the actual corner radius; RE is the effective radius. Table values do not account for the possibility of encroaching into the adjacent lane (see Section 5).



Table 5 assumes encroachment into the second lane, as this scenario is expected to almost always be acceptable for the CITY-BUS design vehicle on streets with two receiving lanes, per the Encroachment Policy (see Section 5). Additionally, **Table 5** assumes the CITY-BUS does not use an “oversteer” method of negotiating the turn; in some cases, using an “oversteer” will greatly reduce the actual and effective radii. These conditions are noted in the table.

Table 5: Relationship between RA and RE for CITY-BUS

		Street A				
		Parking	No	No	Yes	Yes
		Bike Lane	No	Yes	No	Yes
Street B	Parking	Bike Lane				
	No	No	RA = 30' (RE ≈ 30')	RA = 20' (RE ≈ 25')	RA = 20' (RE ≈ 30')*	RA = 15' (RE ≈ 30')*
	No	Yes	RA = 30' (RE ≈ 35')	RA = 30' (RE ≈ 45')*	RA = 20' (RE ≈ 40')*	RA = 10' (RE ≈ 35')*
	Yes	No	RA = 25' (RE ≈ 30')	RA = 20' (RE ≈ 40')*	RA = 15' (RE ≈ 40')*	RA = 5' (RE ≈ 40')
	Yes	Yes	RA = 15' (RE ≈ 30')	RA = 10' (RE ≈ 40')*	RA = 5' (RE ≈ 40')	RA = 5' (RE ≈ 45')

Note: RA is the actual corner radius; RE is the effective radius

*The designer shall consider if negotiating the turn with “oversteering” is appropriate, as it can reduce the RA and RE under these conditions

4.2.5 Truck Aprons

Truck aprons are most common within the center island of a roundabout but should also be considered at intersection corners to accommodate the turning characteristics of larger vehicles while slowing the turning speeds of smaller design vehicles. The truck apron must be designed to be mountable by larger vehicles to accommodate their larger turning radius while smaller vehicles follow the smaller radius along the outside edge of the truck apron.

The outside edge of a truck apron (i.e., closest to the travel lane) is constructed using a mountable curb and should be designed so that the most common vehicle can complete the turn without traversing the truck apron. The radius of the inside edge of the truck apron should be designed to accommodate the effective radius necessary for larger vehicles to complete the turn, including the design vehicle and the check vehicle, considering allowable encroachment (see Section 5). See **Figure 9** for an example of a truck apron used to accommodate the effective radius.

The truck apron is part of the motorist travel way. Truck aprons shall not extend through bike lanes or crosswalks unless they are designed to accommodate these users, and bicycle stop lines and pedestrian accommodations (e.g., curb ramps, crosswalks) must be placed to prevent these users from waiting in the travel way. Colored concrete should be used within the truck apron area to provide a visual contrast from the adjacent roadway and sidewalk. This communicates to drivers of smaller vehicles that this is not an area to utilize. Where widths exceed 15 feet, the intended use of the apron may not be clear, and designers may consider a channelizing island to limit the street crossing distance for pedestrians and bicyclists.



In retrofit conditions, a truck apron that extends all the way to the existing curb line may not be possible without significant stormwater system modifications. In these situations, truck pillows that maintain drainage along the existing curb line may be more practical and feasible.

See DWG 7-1 in the ODOT Multimodal Design Guide for additional design details for truck aprons and truck pillows.

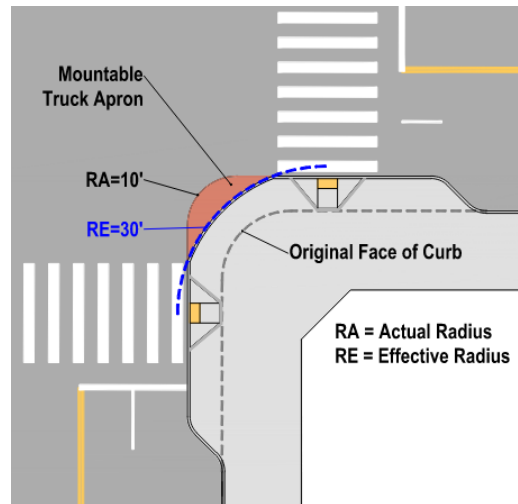

Figure 9: Example of Truck Apron to Accommodate Effective Radius

4.3 Other Design Considerations

Smaller corner radii can result in larger vehicles (e.g., buses, delivery/garbage/construction trucks, street sweepers, and emergency vehicles) requiring encroachment to negotiate the corner (see Section 5). Routine curb mounting by larger vehicles can cause damage to the curb, requiring replacement or repair. Large vehicles mounting the curb can strike pedestrians and bicyclists or damage existing utility and signal infrastructure, requiring constant maintenance and/or relocation. Where existing large corner radii are reduced, existing utility and signal infrastructure may need to be relocated.

5 Encroachment Policy

Designing the corner radius for turning vehicles to encroach into adjacent vehicle lanes is an important strategy to reduce the RA at the intersection corner as illustrated in **Figure 7**. The design and check vehicle along with the functional classification, street enhancements, and intersection control are factors that influence what type of encroachment is feasible. It is important to note that Columbus City Code Section 2131.10 states that right turns “shall be made as close as practicable to the right-hand curb or edge of the roadway.” However, the Ohio Commercial Driver License Manual, Section 2.7.6 – Space for Turns, explains that drivers of large vehicles may encroach into other vehicle lanes; as such, there is flexibility to reduce corner radii and allow for encroachment into other vehicle’s lanes.

Emergency vehicles are assumed to be able to use the entire street width to negotiate turns, including all adjacent and oncoming travel lanes. As such, the following encroachment policy does not apply to emergency vehicles.

The City of Columbus Encroachment Policy is described in the following sections.



5.1 Most Common Vehicle

The intersection corner should be designed so that the *most common vehicle* can negotiate a turn without encroachment into an adjacent or oncoming motor vehicle lane. See **Figure 10**.

5.2 Design Vehicle

The intersection corner should be designed so that the *design vehicle* can negotiate a turn without encroachment into an adjacent or oncoming motor vehicle lane. See **Figure 10**.

There are exceptions for the following situations, described in detail in the following sections:

- Local Street to Local Street
- Stop-Controlled Minor Leg, Uncontrolled Major Leg
- Signalized Intersections

5.2.1 Local Street to Local Street

At the intersection of two local streets, the design vehicle can use the entire width of the departing and receiving lanes, including oncoming travel lanes, to negotiate the turn. See **Figure 11**.

5.2.2 Stop-Controlled Minor Leg, Uncontrolled Major Leg

At intersections where the minor leg is stop controlled and the major leg is uncontrolled, the design vehicle can use the entire width of the minor leg (whether departing or receiving) lanes, including oncoming travel lanes, to negotiate the turn. See **Figure 12**.

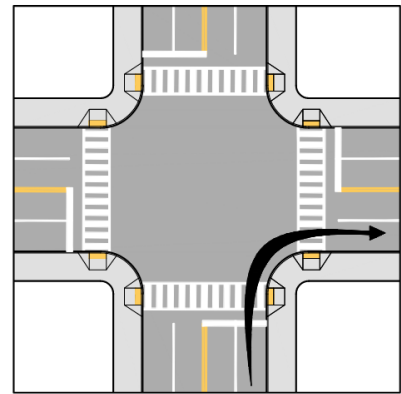

Figure 10: Turn without Encroachment

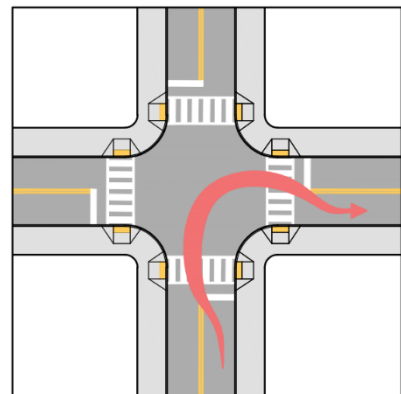

Figure 11: Local-to-Local Encroachment

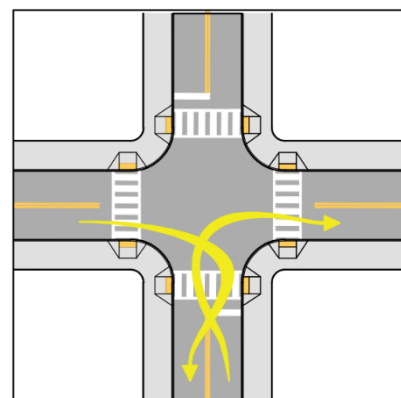

Figure 12: Stop-Controlled Minor Leg Encroachment



5.2.3 Signalized Intersections

At signalized intersections, the design vehicle may use adjacent lanes on the receiving street to complete their turn. The design vehicle may not use oncoming lanes. See **Figure 13**.

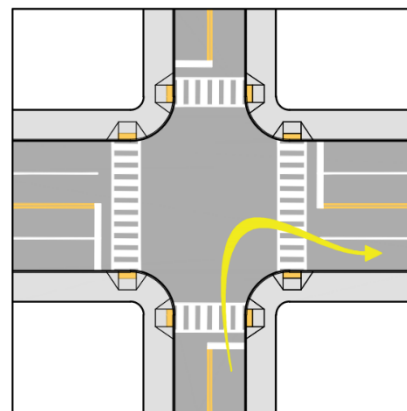

Figure 13: Signalized Intersection Encroachment

5.3 Check Vehicle

The intersection corner should be designed so that the check vehicle can negotiate a turn with encroachment. The following should be considered:

- Check vehicles may use adjacent lanes on the departing and receiving street at all intersections (see **Figure 14**).
- Check vehicles may use the entire street width on Local Streets.
- It may be necessary to set back the stop line on the intersecting street if the check vehicle makes frequent turns at the intersection (see **Figure 15**). This should be limited for use as a strategy only at locations where vehicle encroachment over a stop line would occur frequently and present operational or safety issues if not corrected. See City of Columbus Design Memo 9.05: Stop Line Placement.
- Restricting turns may be necessary, especially when considering the use of traffic calming elements on a Local Street; for example, the planning and placement of a neighborhood traffic circle should influence the selection of a check vehicle and may necessitate turning restrictions. In some cases, a truck apron (see Section 4.2.5) may be used to help provide additional space for the check vehicle when other options are not feasible.

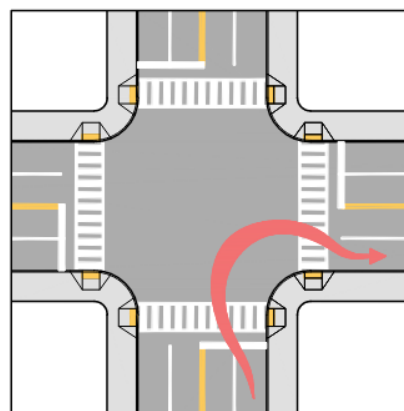

Figure 14: Check Vehicle Encroachment

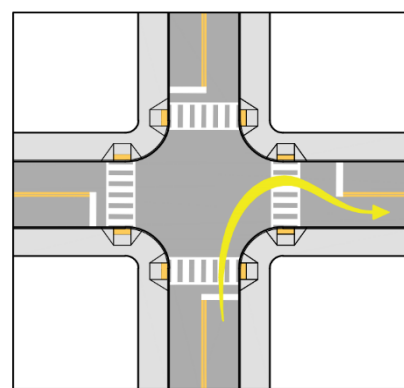

Figure 15: Set Back Stop Line

