

SECTION B-B
NTS

BASIN SIDE
6" CURB WALL OR BASIN WALL

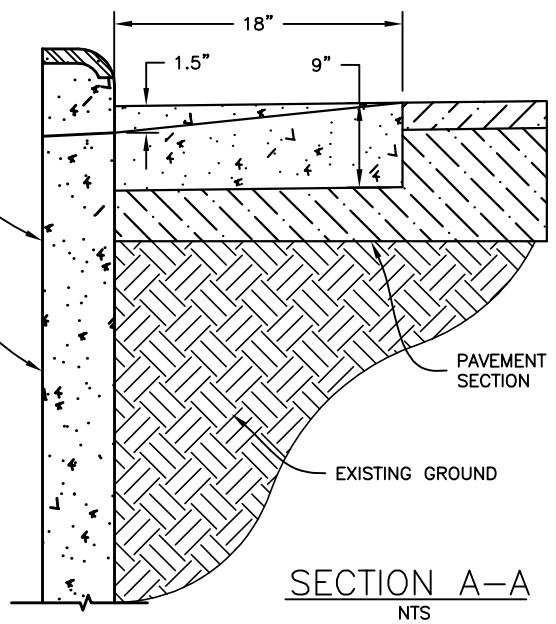

SECTION A-A
NTS

NOTES:
CONCRETE SHALL BE CLASS COC 6

CITY OF COLUMBUS, OHIO
DEPARTMENT OF PUBLIC UTILITIES
DIVISION OF SEWERAGE & DRAINAGE

BASIN INLET
TRANSITION PAD

STANDARD DRAWING
AA-S192

APPROVED: *[Signature]*
SSES MANAGER

8/26/22
DATE

REVISED 8/19/22

PAGE 1 / 1