

Transmission & Distribution
Material & Installation Specification

Loadbreak Connector - 200 Amp

I. Quantity

The base bid shall include the indicated number of 200A, "Loadbreak Connectors" and appropriate accessories included but not limited to silicon lubricant, grounding kits, mounting brackets, straps, abrasives, cleaners, and all necessary items for complete and operational load break terminations.

II. Material

- A. The material shall be equal in quality, design, performance, and appearance to the items specified on drawing TDMIS-1101. All components shall be Elastimold or engineer approved equal.
- B. All steel hardware to be 302 stainless steel.
- C. Connector body shall be a molded rubber or epoxy housing with semi-conductive outer coating supporting load break 200A bushings. Connector shall be capable of load-make and load-break switching.
- D. Load-make and load-break performance shall be at 15 kV three phase and single phase, 8.3kV line to ground, 15 kV max across open contacts. 10 loadmake/break operations at 200 Amps max, with 70 to 80% lagging power factor. 1 fault close operation at 8.3 kV or 14.4 kV; 10000 Amps, rms. sym. 10 cycles (0.1/sec) 1.3 max. asym. factor applies to new or used mating parts (up to maximum designated switching operations).

III. Installation

- A. The installation shall be as appropriate on drawing TDMIS-1101 as related to and called out on TDMIS unit assembly drawings or as needed to complete the circuit or circuit extension and/or circuit taps.

- B. Size and type hardware shall not be substituted without express approval of engineer.
- C. Only qualified personnel with at least 5 years' experience with high voltage terminations, or certificate from a certified training school as approved by COC-DOP may be assigned to terminate MV cables. A resume of personnel's experience shall be submitted to DOP for approval 30 days prior to beginning terminations.
- D. Cables and cable accessories shall be kept clean and dry at all times during termination process. Suitable tents and heaters shall be employed as needed. Person performing cable termination shall clean hands frequently with MEK or other approved solvent to assure semi-conductive materials are not transferred from component to component.
- E. Silicone lubricants shall be applied liberally to separable components. It is recommended that additional tubes of lubricant be on hand.
- F. Connector shall be cleaned and prepped according to the connector manufacturers' directions.
- G. Connectors shall be considered complete when in final position and energized at operating voltage.

IV. Method of measurement

Shall be included with the unit for each ground mounted equipment or apparatus assembly requiring same and shall include all materials, accessories, lubricants, abrasives, tools, labor, equipment, and supervision required for a complete and operational module.

V. Basis of payment

Shall be included with the unit price for associated ground mounted equipment or apparatus.

CITY OF COLUMBUS DEPT. OF PUBLIC UTILITIES – DIVISION OF POWER LOADBREAK CONNECTOR – 200 AMP		
DRAWN BY: AEC	DATE: 01/01/2018	TDMIS-1101
APPROVED: R. SPRITE		
	SHEET 1 of 2	

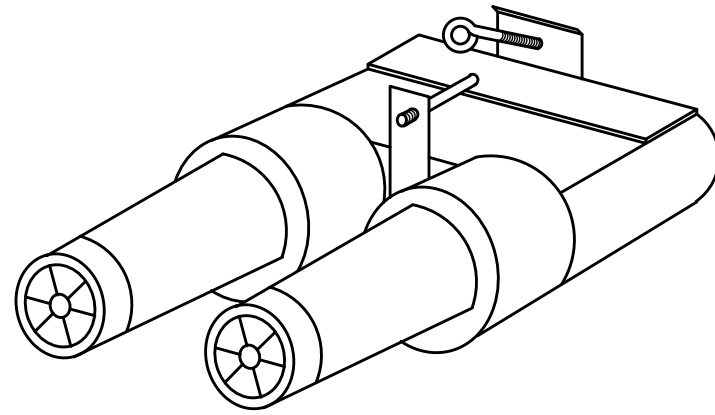

DETAIL 1
PORTABLE FEED-THRU

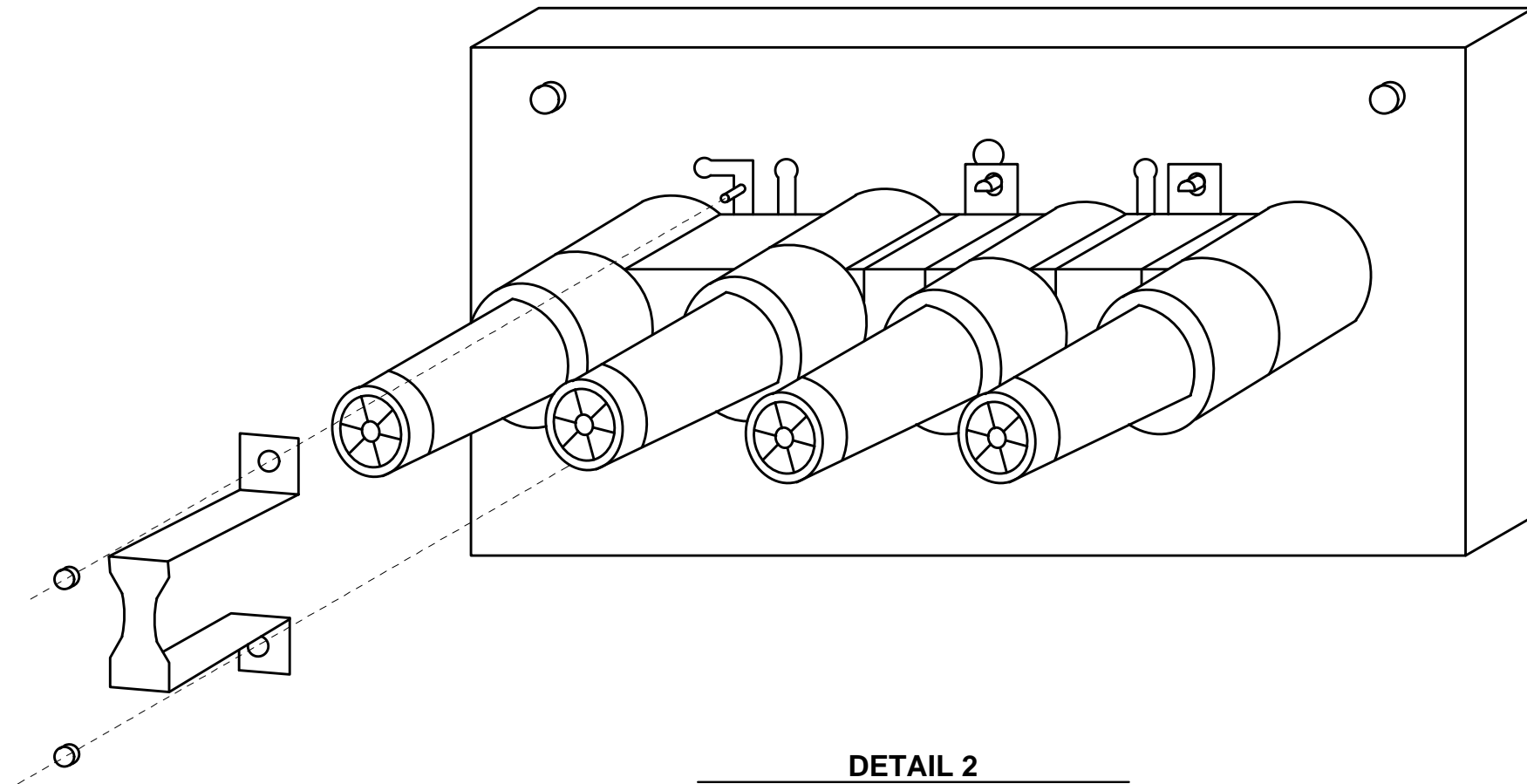

DETAIL 2
JUNCTION

CITY OF COLUMBUS, OHIO
DEPT. OF PUBLIC UTILITIES - DIVISION OF POWER

LOADBREAK CONNECTOR-200 AMP

DRAWN BY: AEC

DATE: 01/01/2018

APPROVED: R. SPRITE

SCALE: NTS

SHEET: 2 OF 2

TDMIS-1101