

**Transmission & Distribution
Material & Installation Specification**

Push Pole Brace Fitting

I. Quantity

The base bid shall include the indicated number of push pole brace fittings and hardware furnished and installed as hereinafter specified.

II. Material

A. Push pole brace shall be galvanized ductile iron for poles 6" to 11" diameter. Brace fitting shall be McClain # PAX138 or engineer approved equal.

III. Installation

A. The installation shall be as shown on drawing TDMIS-114.

IV. Method of Measurement:

Shall be per each and shall include installation of brace pole, excavation, backfill, compaction, rake and or plumbing of pole being braced, equipment, labor and equipment as required for a complete and functional "Push Pole".

V. Basis of Payment

Items	Unit	Description
TDMIS-114	Each	Push pole brace fitting module

CITY OF COLUMBUS DEPT. OF PUBLIC UTILITIES – DIVISION OF POWER PUSH POLE BRACE FITTING		
DRAWN BY: AEC	DATE: 01/01/2018	TDMIS-114
APPROVED: R. SPRITE		
	SHEET 1 of 2	

CODED NOTES:

A PUSH POLE TO BE USED ONLY WHEN IT IS NOT POSSIBLE TO USE A DOWN OR SPAN GUY.

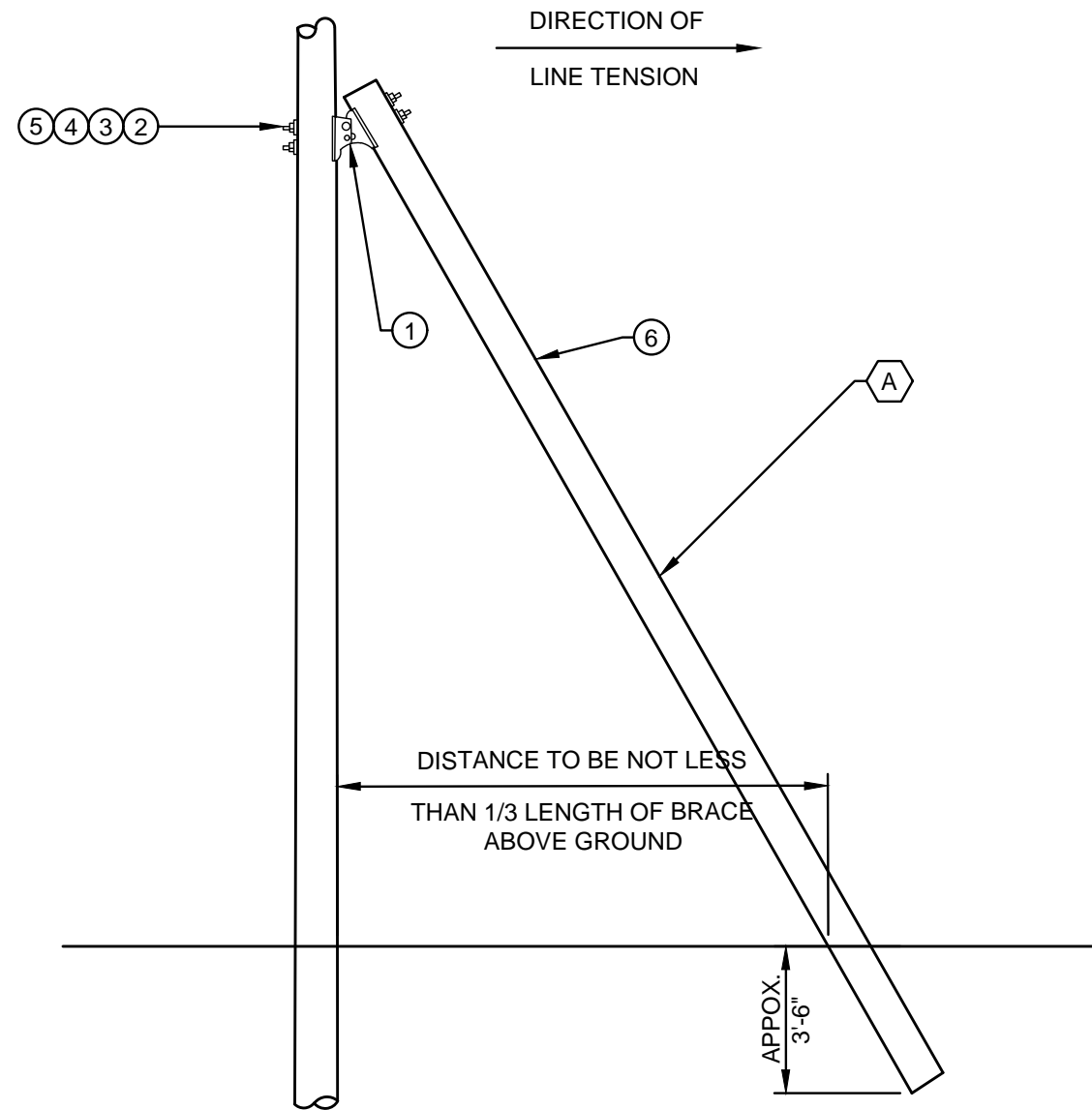

**DETAIL 1
PUSH POLE BRACE FITTING**

ITEM LIST			
ITEM #	DESCRIPTION	PART #	QTY.
①	PUSH BRACE, 6" TO 11" POLE DIA., 0 TO 90°, 3/4" HINGE BOLTS	19282	1
②	BOLT, MACHINE, 3/4" X LENGTH AS REQUIRED	42372	1
③	WASHER, CURVED, GALVANIZED, 11/16" ID, 2 1/4"WX2 1/4"HX3/16"WALL	18897	4
④	WASHER, SPRING LOCK, 13/16" DIA. HOLE, DOUBLE COIL	18894	4
⑤	NUT, SQ. 3/4" -10 UNC GALVANIZED (INCLUDED WITH MACHINE BOLT)	XXXXX	4
⑥	PUSH POLE, SIZE AS REQUIRED	*	1

CITY OF COLUMBUS, OHIO DEPT. OF PUBLIC UTILITIES - DIVISION OF POWER	
PUSH POLE BRACE FITTING	
MPBF	
DRAWN BY: AEC	DATE: 01/01/2018
APPROVED: R. SPRITE	TDMIS-114
SCALE: NTS	