

# Request for Variance

**To:** Greg Fedner  
**From:** Matthew Lorenz  
**Date:** March 13, 2023  
**Re:** 3813-E, Wheatland Avenue – Type II Variance Stormwater Control Practice Grading

---

## Standard

“The side slopes for bioretention facilities shall not exceed 4 (H) to 1 (V).” per the Layout and Geometry Requirements in section 3.4.11 Bioretention Facilities (GI) of the Stormwater Drainage Manual (SWDM) dated May 2021.

## Variance Requested

Type II variance is being requested to construct the sideslopes for the bioretention facility with 3.5 (H) to 1 (V) on the foreslope and 3 (H) to 1 (V) on the backslope.

## Rationale

The variance is being requested to limit the lateral (perpendicular to Wheatland Avenue) distance needed to construct the facility. The proposed sideslopes will help reduce the limits of the facility so that a fence and building in an adjacent development are not impacted. The development is an urban farm being constructed by the Mid-Ohio Food Collective with support from the City of Columbus and Community Development Block Grant (CDBG) funds. A building as shown in the approved site plan is currently under construction that will be impacted by full compliance

The proposed location for the bioretention facility has been adjusted throughout the design in an attempt to avoid the impacts and comply with all the requirements in the SWDM. The location and size have been maximized to the available space while avoiding additional impacts to utility service locations or crossing onto adjacent properties. The City of Columbus does own the adjacent parcel but is managed by another division that does not approve of the facility on their property.

## Alternatives

### Full Compliance

The full compliance alternative is currently shown in the design plans which includes construction limits to construct the bioretention. The construction limits will remove the fence surrounding the development, conflict with a building, and include grading that will lower ground level within the



developed space impacting the use.

After construction is complete the fence could be reinstalled but will be at a lower elevation and will not provide the screening as requested by the community during the site compliance process. The foundation of the building will need to be protected by a retaining wall due to grade change of more than 1 foot.

Expanding the basin to the south was considered too meet full compliance without impacting the development. As noted in the previous section this property is controlled by a separate City division that is not supporting the development. In previous meetings with the division, impacts were strongly discouraged. Therefore, this will be considered as a separate property since it is unfeasible to gain approval for use of the property for a stormwater facility. This property operates as the West Side Health and Wellness Center with a parking lot to support the facility on the north side.

#### Minimal Impact

The minimal impact will increase the sideslope on the development side, backslope, to 3 (H) to 1 (V). This will place the construction limits close to the edge of the building but will remove the fence surrounding the development. Slopes below the ponding limits will remain at 4 (H) to 1 (V) to maintain the volume.

The maintenance required for the facility will not be negatively impacted by the requested variance as the plantings do not require mowing and are noted to be pruned by hand twice a year as part of the maintenance plan.

#### Preferred

Since the goal of the variance is to limit impacts to the development the preferred alternative is to adjust the sideslopes to as close to compliance as possible while still avoiding the fence. The street side, foreslope, of the facility is proposed to have 3.5 (H) to 1 (V) slope and will be located behind the roadway curb and adjacent 6' sidewalk. The proposed foreslope is steeper than 4 (H) to 1 (V), but will provide for more clearance from the building and the fence will not be removed. The development side, backslope, is proposed to have a 3 (H) to 1(V) slope bordered by a fence surrounding the development site. Slopes below the ponding limits will remain at 4 (H) to 1 (V) to maintain the volume.

The maintenance required for the facility will not be negatively impacted by the requested variance as the plantings do not require mowing and are noted to be pruned by hand twice a year as part of the maintenance plan. The steeper foreslope will also provide space for maintenance around the facility.

#### **Support**

The Ohio Environmental Protection Agency (OEPA) provides some guidance on bioretention facilities, [2.9 Bioretention](#), but does not recommend a maximum sideslope. It does note a 4:1 or flatter sideslope when the slope is used as pretreatment for the facility that does not apply to this project. In other sections, [2.6 Wet Extended Detention Basin](#) and [2.7 Dry Extended Detention Basin](#), the side slopes are noted to not be steeper than 3:1.



The Department of Public Service Standard Construction Drawings, [2110](#) and [2300](#), indicate a maximum sideslope of 3:1. These are applicable to this project due to the roadway curb and sidewalk and are used throughout the City. The same slopes are maintained by the City and property owners.

Landscaping will not be a maintenance concern for the slopes due to the plantings used to cover the entire slopes. The proposed planting of Tara Prairie Dropseed is a native prairie grass that is drought tolerant and the root structure is suitable for slopes and prevents weed growth. The root structure “spreads 1-2 ft in the upper soil but many extend vertically downward 4-5 ft” ([Weaver 1958](#)), this will prevent slope erosion.

**Attachments:**

The following documents and sources have been included for information with this request.

1. E03822 Basin Grading Exhibit
  - a. The first sheet shows combinations of different sideslopes that were evaluated in order to meet the goal of not impacting the adjacent development.
  - b. The next sheets are taken from the most recent plans with location of the sections used on the first sheet. Limits for Full Compliance, Minimal Impact, and Preferred are noted.
2. Pages from E03813-Wheatland-Plan-STG3
  - a. Selected sheets from the current plans showing the post construction stormwater control facilities, maintenance notes, and planting plan.

**Plantings**

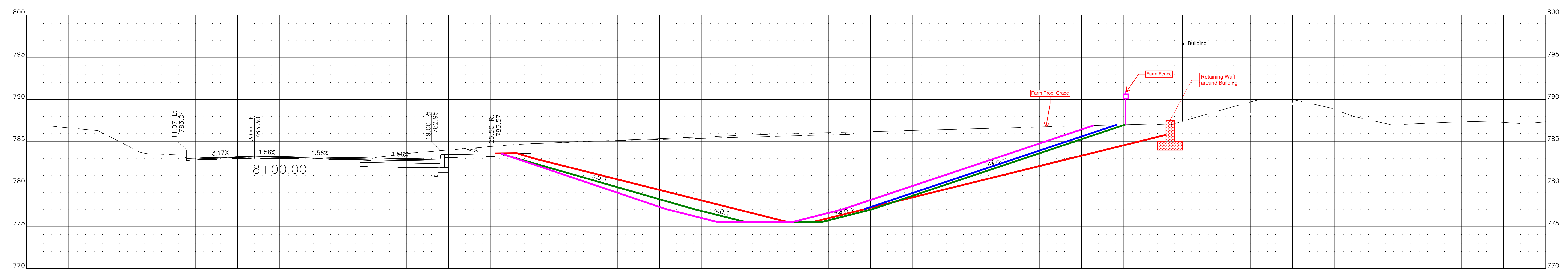
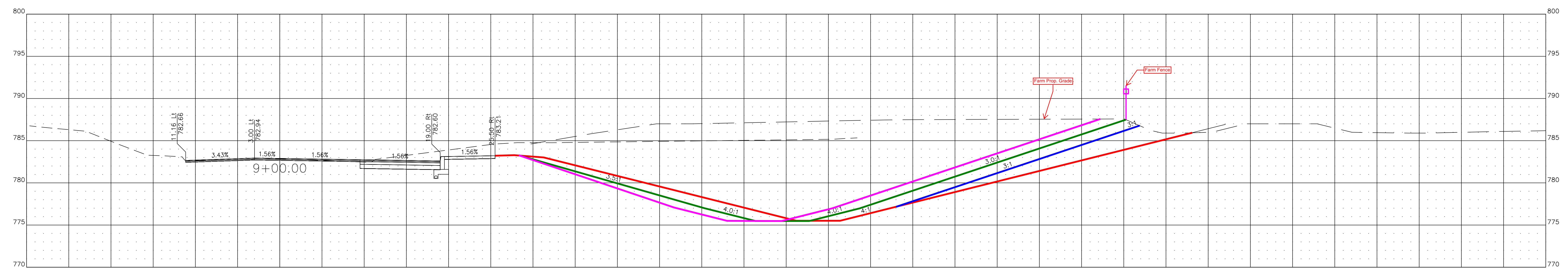
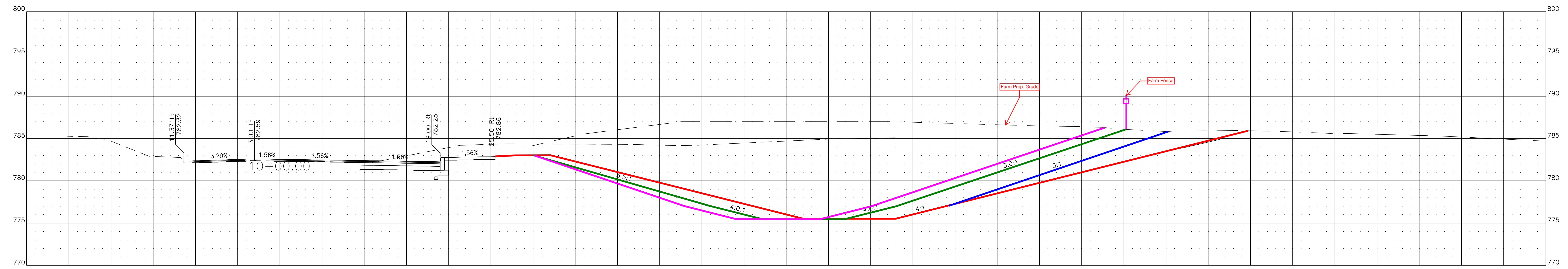

*Figure 1 Prairie Dropseed*



*Figure 2 Blue Flag Iris*





- Foreslope and Backslope Adjustment to 3:1
- Full Compliance Current Basin Grading to 4:1
- Minimal Impact Basin Backslope Adjustment To 3:1
- Preferred Basin Foreslope Adjustment to 3.5:1 & Backslope Adjustment To 3:1

| PLAN SHEET REFERENCES |                                    |
|-----------------------|------------------------------------|
| SHEET #               | DESCRIPTION                        |
| 12-##                 | Erosion Control                    |
| 22,24,26,28,31,33     | Plan & Profile Subsummary          |
| 34-70                 | Cross Sections                     |
| 71-77                 | Intersection and Curb Ramp Details |
| 78-81                 | Driveway Details                   |
| 82-85                 | Wall Details                       |
| 91-110                | Power Relocation Plan              |
| 111-126               | Lighting Plan                      |
| 128-154               | Right-of-Way                       |

Note: All Prop. Curb Walls shall have a 12" reveal. See Detail Sheet 3

| Length (FT) | Side | End Offset | End Station | Begin Offset | Begin Station |
|-------------|------|------------|-------------|--------------|---------------|
| 98.60       | L    | 15.50      | 5+55.00     | 6+13.60      | 15.50         |
| 35.72       | L    | 15.50      | 6+17.60     | 6+53.32      | 15.50         |
| 23.31       | L    | 15.50      | 6+57.55     | 6+75.18      | 15.50         |
| 19.14       | L    | 16.50      | 10+39.12    | 10+58.26     | 16.50         |

**STATION EQUATIONS LEGEND**

- Violet St @ Sta: 105+00.00 = Wheatland Ave @ Sta: 6+85.00
- Non-Residential Drive @ Sta: 1200+00.00 = Wheatland Ave @ Sta: 5+88.15

**LEGEND**

- Encroachment
- Visually Compliant
- Full Depth Pavement, Refer to Typical Sections (Sheet 3-5)
- Permanent Pavement Replacement, Refer to Typical Sections (Sheet 3-5)
- Bioretention Area (See Sheet 14)

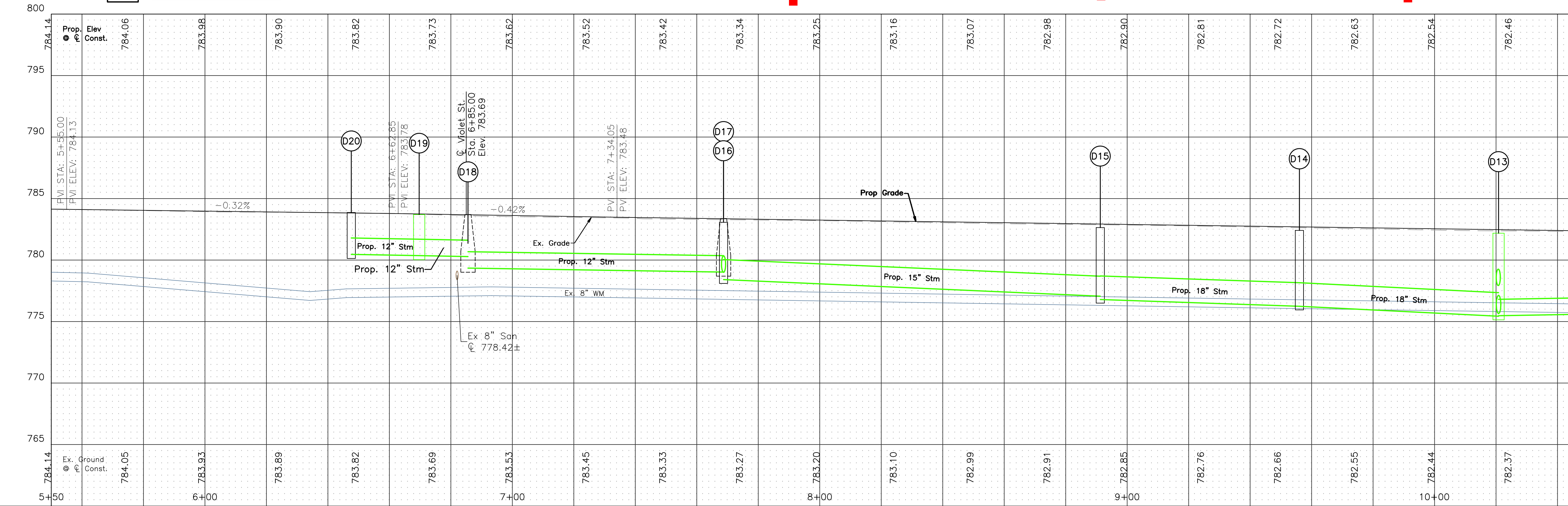
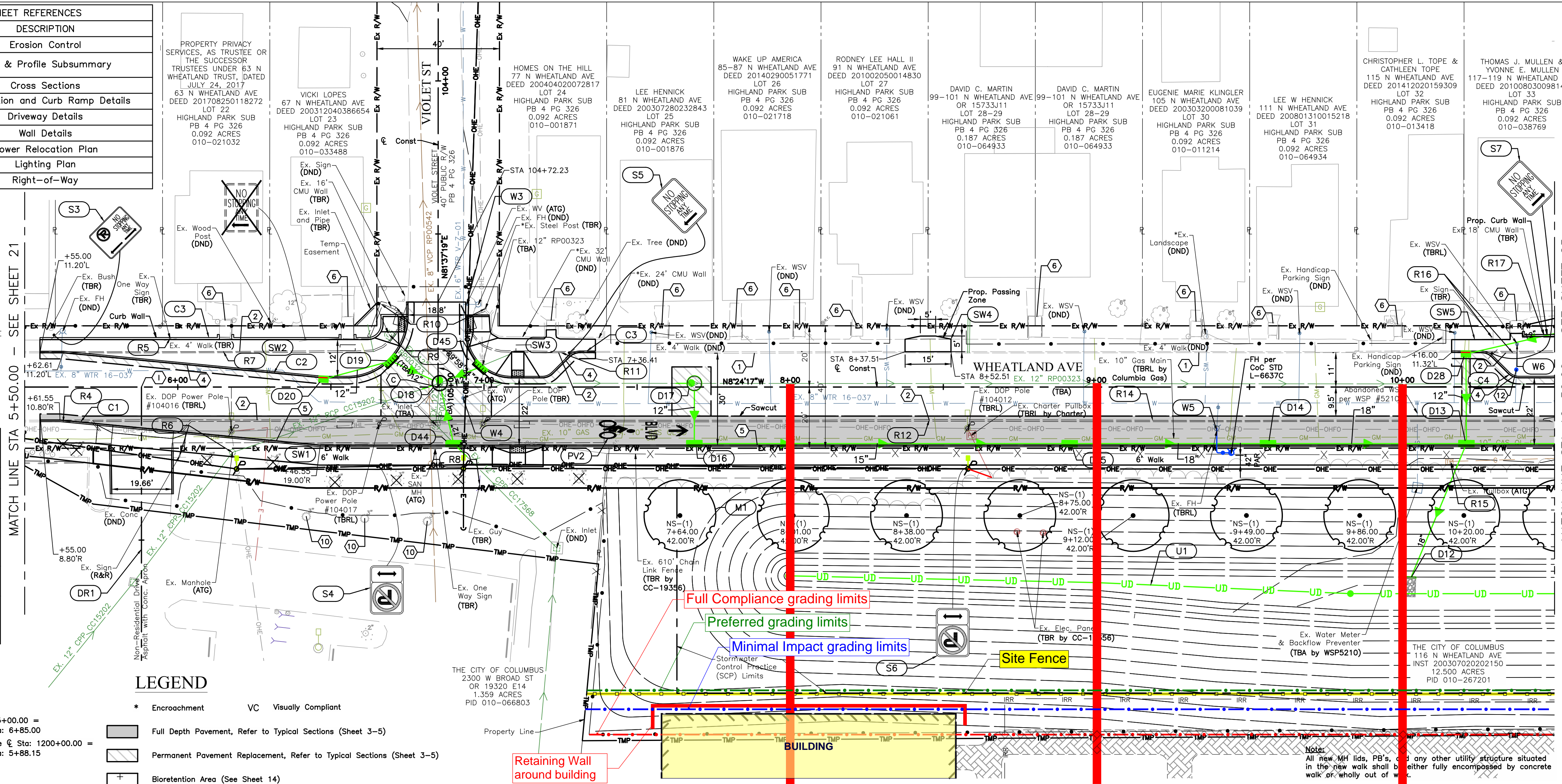

- KEYNOTES**
- Ex. Conc. Curb, Straight (DND)
  - Ex. Conc. Curb, Straight (TBR)
  - Ex. Edge of Pavement (TBR)
  - Prop. Curb, Straight-4" Reveal
  - Prop. Curb, Straight-6" Reveal
  - Ex. Conc. Stairs w/ Railing (DND)
  - Prop. Curb Break (See Sheet 92)
  - Ex. San Manhole (ATG)
  - Ex. San Manhole (DND)
  - Ex. Landscape (DND)
  - Ex. Landscape (TBR)
  - Prop. WSV Relocation
  - Guardrail, Type MGS, Quarter Post Spacing
  - Guardrail, Type MGS, Half Post Spacing

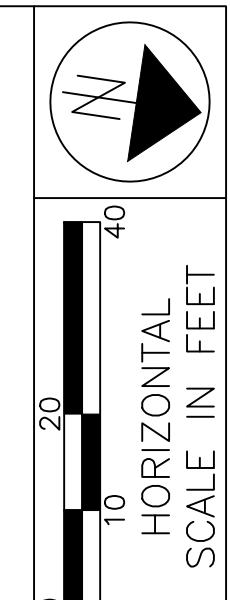

| CIP NO.       | EDS | CHECKED |
|---------------|-----|---------|
| 530303-100002 |     | JDB     |
| PID NO.       |     |         |
| N/A           |     |         |

| Tag | Qty | Unit | Item                 | 661 | Scientific Name            | Common Name       | Size | Cond.     | Remarks           |
|-----|-----|------|----------------------|-----|----------------------------|-------------------|------|-----------|-------------------|
| NC  | 1   | EA   | Deciduous Tree, 2.5" |     | Nyssa sylvatica 'Wildfire' | Wildfire Blackgum | B&B  | 2.5" Col. | Full, well-shaped |

**WHEATLAND AVENUE PLAN & PROFILE**  
 STA 5+50.00 TO STA. 10+50.00

**IMPROVEMENT OF WHEATLAND AVE**  
 FROM W BROAD STREET TO N OAKLEY AVENUE

Last Saved By: Damian, 1/19/2023 1:22:36 PM  
 G:\DC\Projects\OH\_City\_of\_Columbus\082437\_Improvement\4.0 Disciplines\Civil\Cadd\Cadd\82437\_GPO01.dwg Plotted By: Damian, Eric Plotted: January 19, 2023, 1:26:55 PM

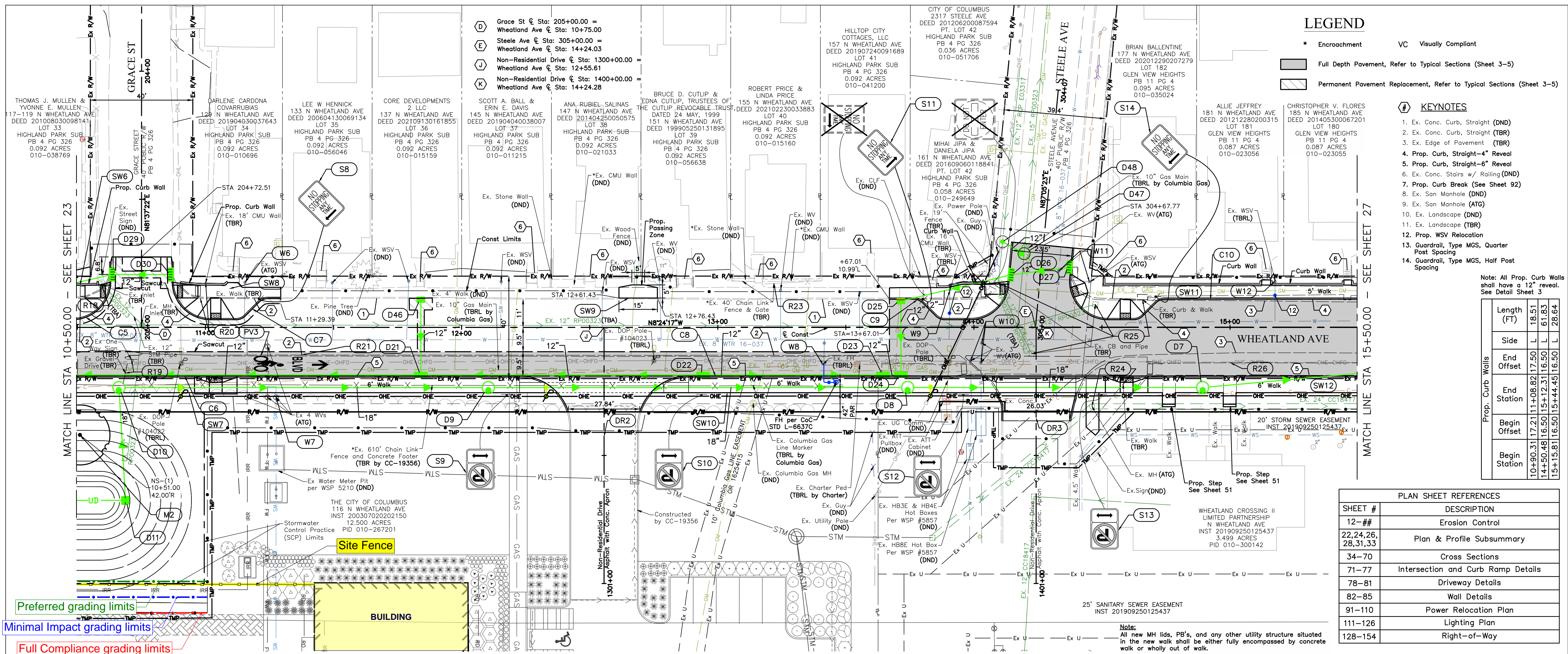

### LEGEND

- \* Encroachment
- VC Visually Compliant
- Full Depth Pavement, Refer to Typical Sections (Sheet 3-5)
- Permanent Pavement Replacement, Refer to Typical Sections (Sheet 3-5)

- ### KEYNOTES
1. Ex. Conc. Curb, Straight (DND)
  2. Ex. Conc. Curb, Straight (TBR)
  3. Ex. Edge of Pavement (TBR)
  4. Prop. Curb, Straight-4" Reveal
  5. Prop. Curb, Straight-6" Reveal
  6. Ex. Conc. Stairs w/ Railing (DND)
  7. Prop. Curb Break (See Sheet 92)
  8. Ex. San Manhole (DND)
  9. Ex. San Manhole (ATG)
  10. Ex. Landscape (DND)
  11. Ex. Landscape (TBR)
  12. Prop. WSV Relocation
  13. Guardrail, Type MGS, Quarter Post Spacing
  14. Guardrail, Type MGS, Half Post Spacing

Note: All Prop. Curb Walls shall have a 12" reveal. See Detail Sheet 3

| Prop. Curb Walls | Length (FT) | Side | End Offset | End Station | Begin Offset | Begin Station |
|------------------|-------------|------|------------|-------------|--------------|---------------|
|                  | 18.51       | L    | 17.50      | 10+90.31    | 17.2111      | 10+90.31      |
|                  | 16.50       | L    | 16.50      | 14+50.48    | 15+12.31     | 14+50.48      |
|                  | 16.50       | L    | 16.50      | 15+15.81    | 16.50        | 15+15.81      |
|                  | 28.64       | L    | 16.50      | 15+44.45    | 15+44.45     | 15+44.45      |

### PLAN SHEET REFERENCES

| SHEET #           | DESCRIPTION                        |
|-------------------|------------------------------------|
| 12-##             | Erosion Control                    |
| 22,24,26,28,31,33 | Plan & Profile Subsummary          |
| 34-70             | Cross Sections                     |
| 71-77             | Intersection and Curb Ramp Details |
| 78-81             | Driveway Details                   |
| 82-85             | Wall Details                       |
| 91-110            | Power Relocation Plan              |
| 111-126           | Lighting Plan                      |
| 128-154           | Right-of-Way                       |

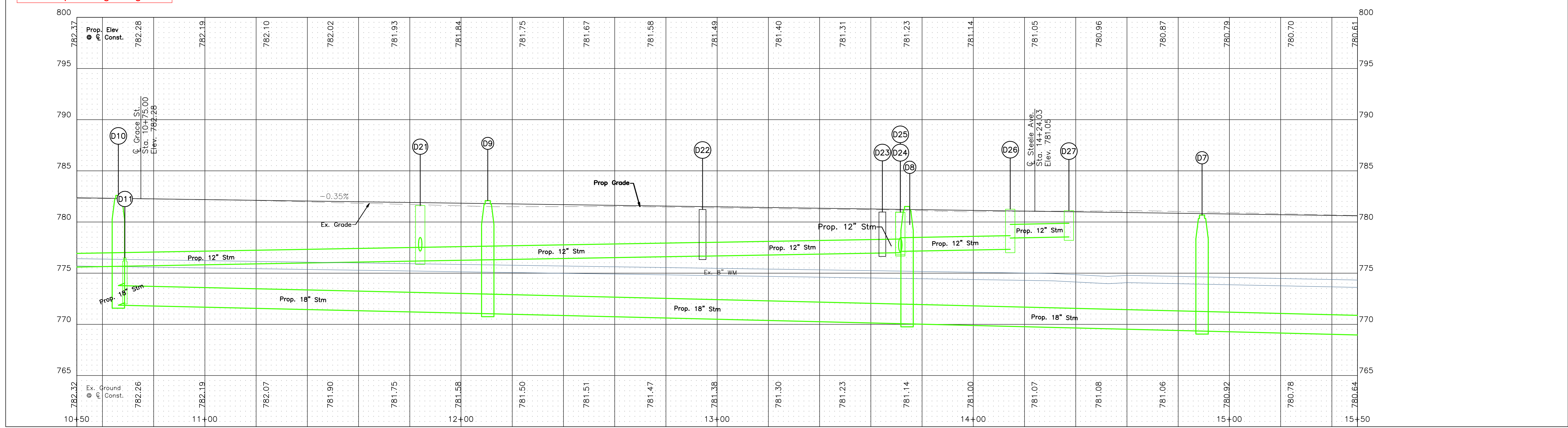

**WHEATLAND AVENUE PLAN & PROFILE**  
 FROM W BROAD STREET TO N OAKLEY AVENUE  
 STA 10+50.00 TO STA. 15+50.00  
**3813-F**  
**25**  
**148**

Layout Tab Name: Details, Images: . Xrefs: 82437\_Title Block.dwg; 21061\_BD002.dwg; 21061\_BD001.dwg; 21061\_BE001.dwg; 82437\_BND\_20220822.dwg; 82437\_BND\_2023 12:14:24 PM  
 Last Saved By: kline, 1/27/2023 12:14:24 PM  
 P:\21061\_CoC Wheatland Avenue Improvements\CADD\BASE\21061\_BMP Plan and Notes.dwg Plotted: January 27, 2023, 12:17:33 PM

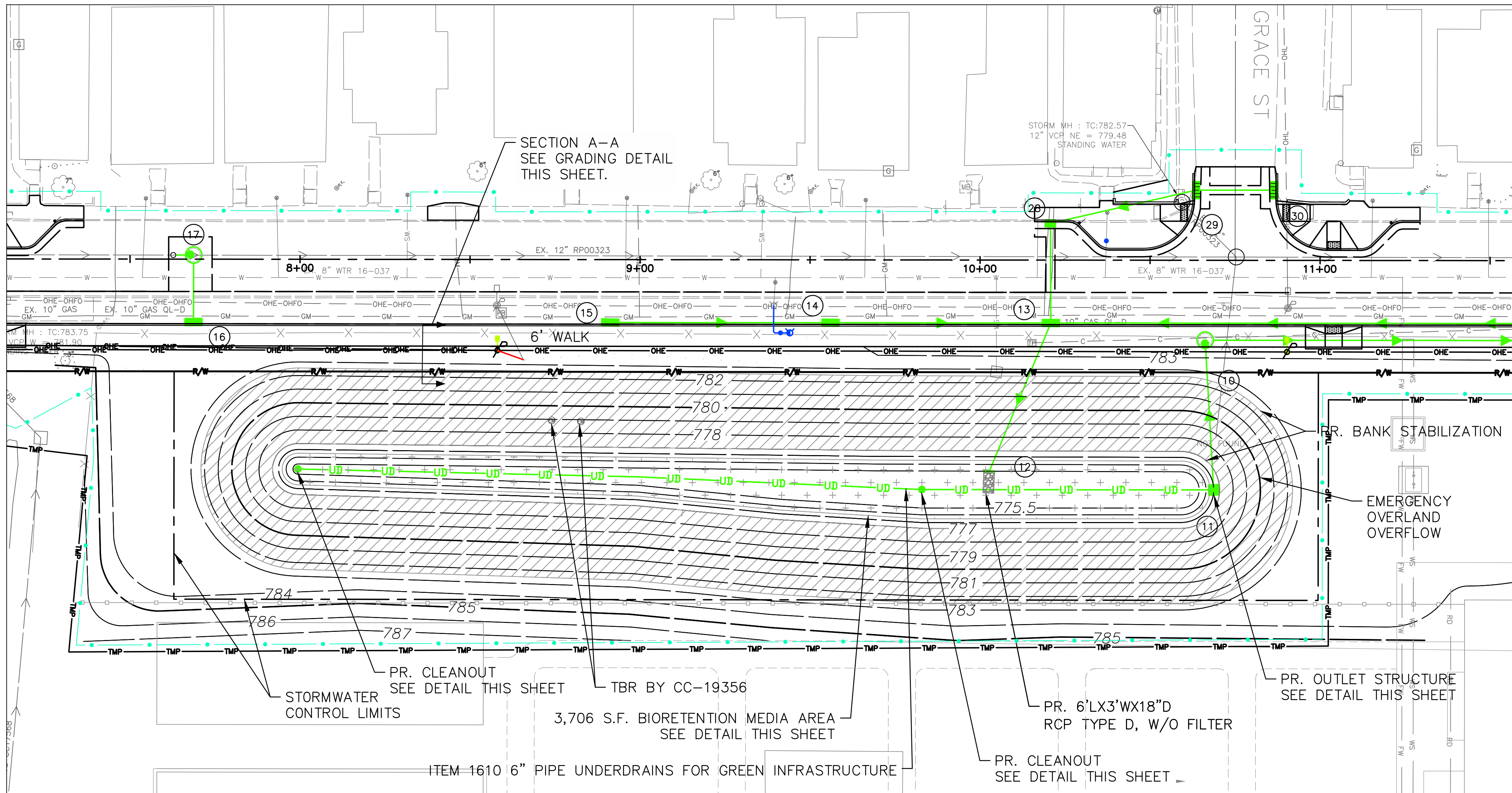

**LEGEND**

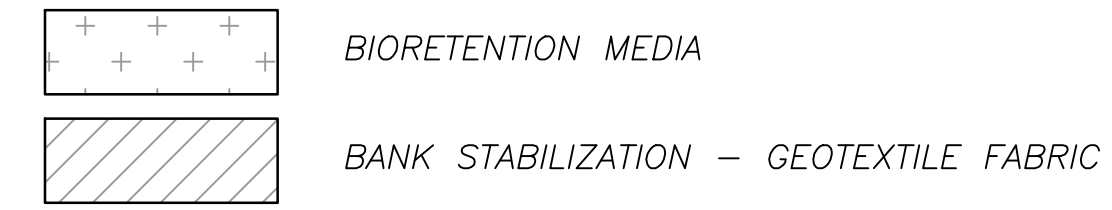

**NOTES**

- BIORETENTION AREA SHALL NOT BE INSTALLED UNTIL SITE IS STABLE FROM SEDIMENTATION.
- FOR ADDITIONAL INFORMATION ON BIORETENTION AREAS SEE THE CITY OF COLUMBUS STORMWATER DRAINAGE MANUAL SECTION 3.4.11
- PLANTING SOIL (FILTER MEDIA) REQUIREMENTS:  
SEE CITY OF COLUMBUS GREEN INFRASTRUCTURE SUPPLEMENTAL SPECIFICATIONS 1604 BIORETENTION SOILS
- MULCHING LAYER: A TOP LAYER OF 3" MINIMUM OF SHREDDED HARDWOOD MULCH SHALL BE PLACED ABOVE PLANTING SOIL WHERE GRASS IS NOT PLANTED.
- UNDERDRAIN
  - INSTALL 6" DIA. PERFORATED PIPE UNDERDRAIN MEETING THE REQUIREMENTS OF ITEM 605.
  - PROVIDE GRANULAR BACKFILL TO AT LEAST 4 INCHES ABOVE THE OUTSIDE DIAMETER OF THE PIPE.
  - PROVIDE A CLEAN OUT ACCESS AT THE TERMINATION POINTS FOR EACH UNDERDRAIN RUN. CLEAN OUT SHALL BE 4" NON-PERFORATED PVC PIPE EXTENDING TO THE SURFACE OF THE PLANTING BED WITH A REMOVABLE SEALED WATERTIGHT CAP.
- FILTER LAYER
  - PROVIDE PERMEABLE NON-WOVEN GEOTEXTILE WITH A FLOW RATE EXCEEDING 110 GPM (ASTM 4491), PUNCTURE STRENGTH 125LB (ASTM D-751), MULLEN BURST STRENGTH 400 PSI (ASTM D-1117), TENSILE STRENGTH 300 LB (ASTM D-1682)
  - PROVIDE GRANULAR LAYER OF NO. 57 AGGREGATE
- AFTER THE SLOPE OF THE BASIN IS SET, THE UPPER BANK ABOVE NORMAL WATER ELEVATION SHOULD BE STABILIZED QUICKLY TO PREVENT EROSION WITH STRAW BLANKETS, JUTTE MATTING, OR SIMILAR GEOTEXTILE UNTIL PLANTINGS ARE INSTALLED.

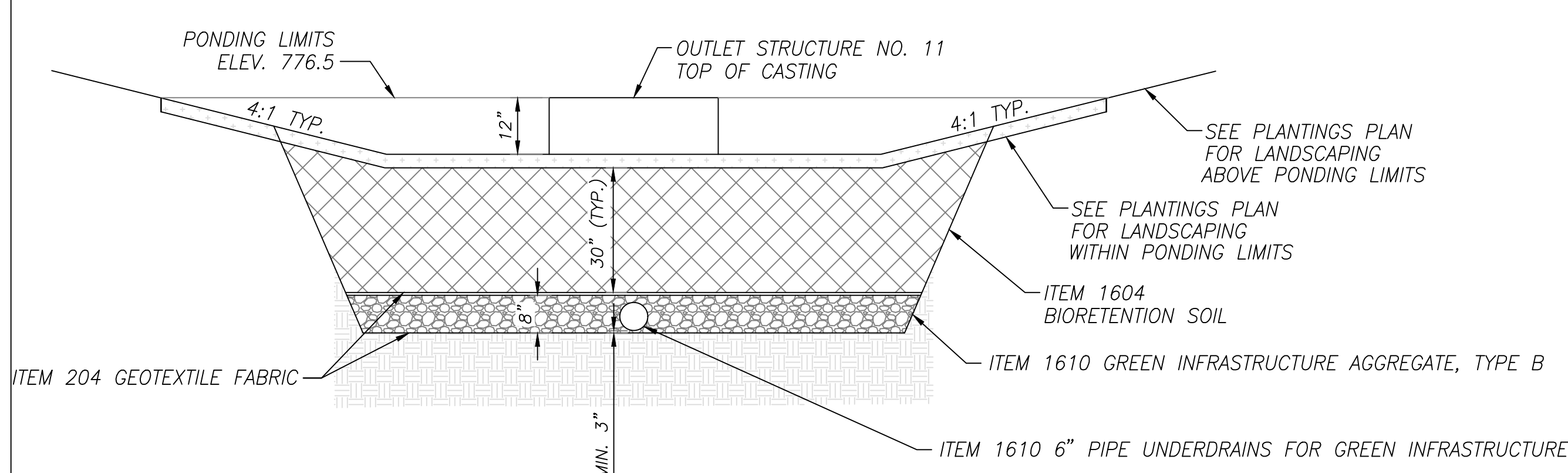

**BIORETENTION AREA DETAIL**  
NO SCALE

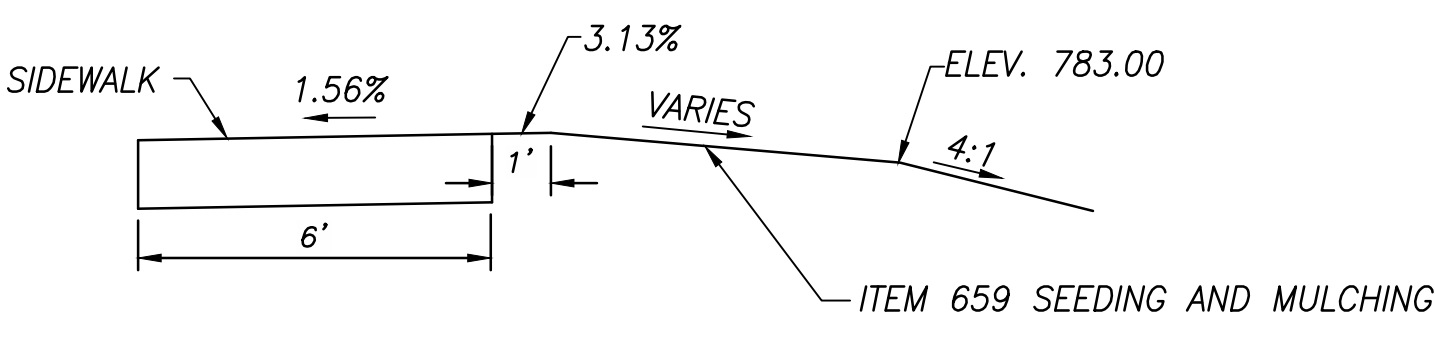

**SECTION A-A GRADING DETAIL**  
NO SCALE

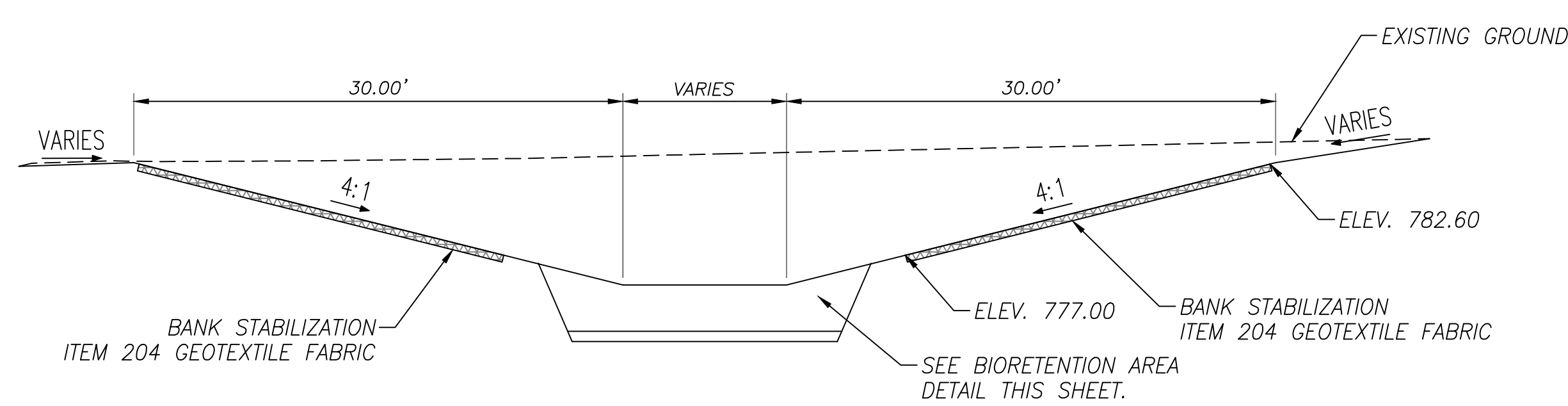

**BIORETENTION AREA TYPICAL SECTION**  
NO SCALE

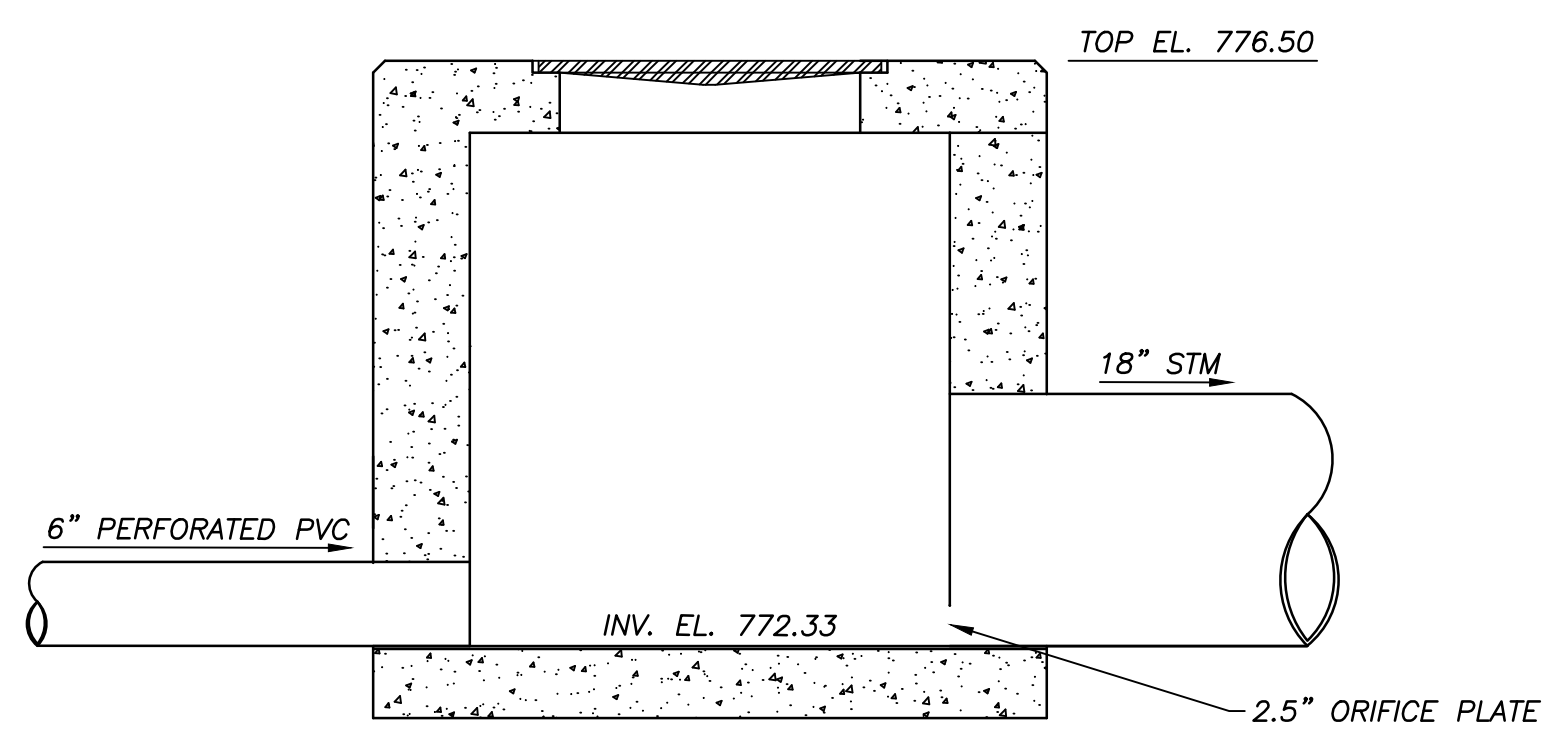

**OUTLET STRUCTURE #11 DETAIL**  
NO SCALE  
MODIFIED CATCH BASIN AA-S133A

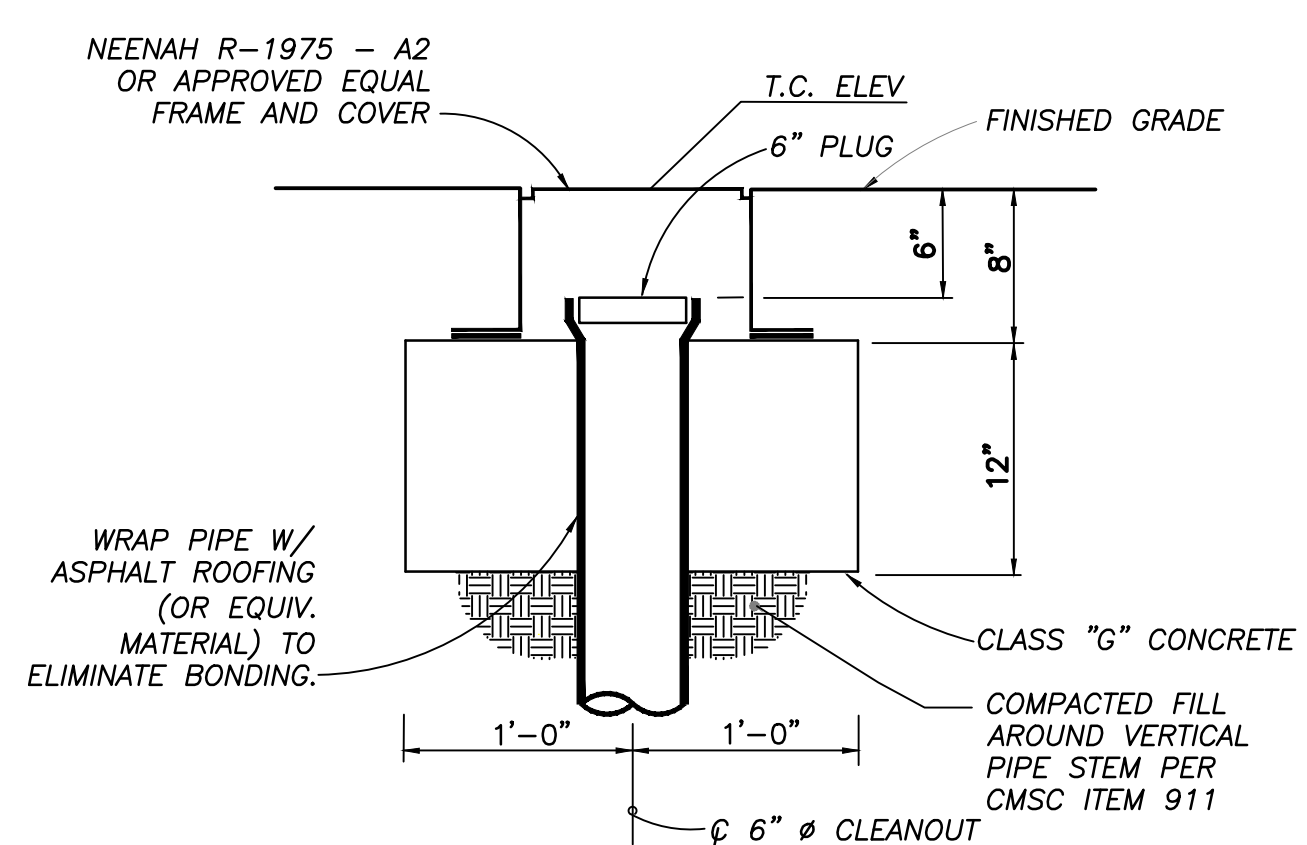

**CLEAN OUT DETAIL**  
NO SCALE

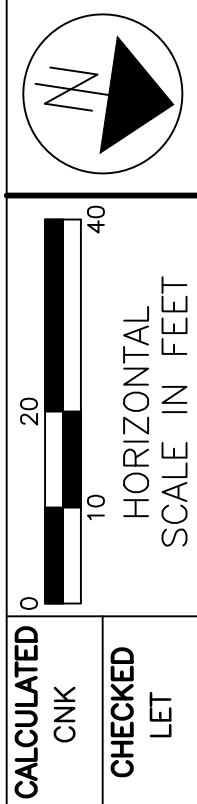

CALCULATED 0  
CNK  
CHECKED  
LET

CIP NO.  
530303-100002  
PID NO.  
N/A

**SUMMARY OF POST CONSTRUCTION  
STORMWATER CONTROL FACILITIES**

IMPROVEMENT OF WHEATLAND AVE  
FROM W BROAD STREET TO N OAKLEY AVENUE

3813-E

14  
148

## BMP MAINTENANCE NOTES:

THE CITY OF COLUMBUS REQUIRES MAINTENANCE FOR ALL STORMWATER CONTROL PRACTICES PER THE INSPECTION & MAINTENANCE GUIDANCE FOR STORMWATER CONTROL PRACTICES MANUAL. THE FOLLOWING ARE GUIDELINES FOR BIORETENTION FACILITIES. A BIORETENTION INSPECTION FORM MUST BE COMPLETED DURING ALL INSPECTIONS AND IS INCLUDED IN APPENDIX B OF THE MANUAL. THE BIORETENTION INSPECTION FORM MUST BE USED AS A GUIDELINE FOR EVALUATING THE CONTINUED FUNCTIONALITY AND AESTHETICS OF THE FACILITY. THE INSPECTION FORM PROVIDES A CHECKLIST OF THE KEY ASSESSMENT METRICS THAT MUST BE REVIEWED DURING EACH INSPECTION. THE FORM IS BASED ON A RATING SCALE OF 1 TO 5 WITH 1 INDICATING POOR CONDITIONS, AND 5 INDICATING IDEAL CONDITIONS. IN ADDITION TO THE QUANTIFICATION OF EACH ASSESSMENT METRIC, THE FORM ALSO PROVIDES A SPACE FOR COMMENTS AND RECOMMENDED AS NEEDED MAINTENANCE.

### ESTABLISHMENT PERIOD INSPECTION AND MAINTENANCE FOR BIORETENTION FACILITIES:

THE ESTABLISHMENT PERIOD TYPICALLY LASTS TWO FULL GROWING SEASONS AFTER PLANTS ARE INSTALLED. DURING THIS PERIOD, MONTHLY INSPECTIONS ARE REQUIRED. DEFICIENCIES NOTED DURING THE INSPECTIONS MUST BE REMEDIED DURING THE INSPECTION IF POSSIBLE. MAINTENANCE TASKS MUST BE PERFORMED DURING INSPECTIONS.

MONTHLY INSPECTIONS:

- RECENT RAINFALL EVENTS AND THE CURRENT WEATHER MUST BE DOCUMENTED.
- THE OVERALL CONDITION OF THE BIORETENTION FACILITY MUST FIRST BE ANALYZED, FOCUSING PRIMARILY ON THE VEGETATION PRESENT IN THE PLANTING AREA, AS WELL AS THE GENERAL AESTHETICS OF THE BASIN. PLANTS SHOULD APPEAR HEALTHY WITH FEW WEEDS/INVASIVE SPECIES. CHECK FOR PRESENCE OF ANY TRASH, DEBRIS, OR CHEMICAL ACCUMULATION, INCLUDING MOSQUITO PROLIFERATION. ENSURE PLANT COVER IS INCREASING AS THE PLANTS REACH MATURITY.
- THE INLETS AND OVERFLOW STRUCTURES MUST BE EXAMINED FOR ANY BLOCKAGES OR OBSTRUCTIONS TO FLOW ENTERING OR EXITING THE BASIN. THE PRE TREATMENT AREA LOCATED AT EACH INLET MUST THEN BE CHECKED FOR EXCESSIVE SEDIMENT ACCUMULATION.
- THE PERIMETER OF THE FACILITY MUST BE INSPECTED FOR ANY EROSION OR UNDERCUTTING ALONG THE BASIN BOTTOM OR SIDE SLOPES, IN ADDITION TO VERIFYING SLOPE STABILITY OR ANY CHANGES IN GRADING. LOCATIONS OF GULLYING, SOIL INSTABILITY, OR UNVEGETATED REGIONS ALONG THE SLOPES DUE TO EROSION MUST BE IDENTIFIED AND REMEDIED.
- THE FUNCTIONALITY OF THE BIORETENTION MEDIA MUST BE EXAMINED DURING EACH MONTHLY INSPECTION. IN ACCORDANCE WITH THE REGULARLY SCHEDULED MAINTENANCE, BIORETENTION FACILITIES WITH MULCH MUST BE MAINTAINED TO PROVIDE AN ADEQUATE, EVEN MULCH COVER THROUGHOUT THE ENTIRE PLANTING AREA. THE SOIL MOISTURE MUST APPEAR AVERAGE, WITH NO CRACKS OR PROLONGED PONDING. DURING STORM EVENTS, BIORETENTION FACILITIES MUST FULLY DRAIN WITHIN 40 HOURS TO MAINTAIN PROPER VECTOR (MOSQUITO) CONTROL. THE SOIL MUST ALSO BE CHECKED FOR COMPACTION, WHICH MAY REDUCE INFILTRATION RATES AND EVENTUAL PONDING CONCERNS. EXCESSIVE SEDIMENT DEPOSITS IN THE BOTTOM OF THE BASIN MUST BE REMOVED REGULARLY TO PROMOTE THE FUNCTIONALITY OF THE BASIN AS A STORMWATER TREATMENT SYSTEM.

MAINTENANCE TASKS AND SCHEDULE:

MAINTENANCE TASKS DURING THE ESTABLISHMENT PERIOD TYPICALLY INCLUDE:

- WATERING (ONE/WEEK MARCH–OCTOBER)
- WEEDING (ONE/MONTH MARCH–OCTOBER)
- TRIMMING (ONE/WEEK MARCH–OCTOBER)
- TRASH & DEBRIS REMOVAL (ONCE/MONTH ALL YEAR)
- MINOR SEDIMENT/LEAF REMOVAL (ONCE/MONTH ALL YEAR)
- MINOR EROSION REPAIRS (ONCE/MONTH ALL YEAR)
- MULCH REPLACEMENT (ONCE IN FEBRUARY–MAY)
- PLANT PRUNING (ONCE IN MARCH–MAY AND ONCE IN OCTOBER–DECEMBER)

#### WATERING

DURING THE ESTABLISHMENT PERIOD, ROUTINE WATERING DURING THE GROWING SEASON IS CRUCIAL IN PROMOTING THE GROWTH AND SUCCESS OF THE NEWLY PLANTED VEGETATION. WATERING MUST BE CONDUCTED WEEKLY BETWEEN MAY AND OCTOBER DURING THE ESTABLISHMENT PERIOD.

#### WEEDING

WEEDING IS NECESSARY IN PREVENTING THE PROLIFERATION OF UNWANTED SPECIES, WHICH MAY CHOKER OR HINDER THE GROWTH OF BIORETENTION PLANTS. ALL PLANTS THAT ARE NOT SPECIFIED ON THE PERMITTED PLANTING PLAN MUST BE REMOVED BY HAND, SUCH THAT NO MORE THAN 5% WEED COVERAGE IS PRESENT AT ANY GIVEN TIME. WEEDS MUST BE REMOVED ENTIRELY, INCLUDING ALL ROOTS AND ROOT FRAGMENTS, BEFORE THE PLANTS SET SEED TO MINIMIZE FURTHER SPREAD OF THE SPECIES. PROPER MULCH COVER THROUGHOUT THE GROWING SEASON MUST BE MAINTAINED TO AID IN PREVENTING THE GROWTH OF WEEDS. PROACTIVE WEEDING IS ESPECIALLY CRITICAL DURING THE ESTABLISHMENT PERIOD.

#### TRIMMING

BECAUSE MANY BIORETENTION FACILITIES ARE LOCATED IN PUBLIC AREAS SUCH AS PARKS, RIGHTS OF WAY, OR NEIGHBORHOODS, ROUTINE TRIMMING OF SEEDED LAWN AREAS SURROUNDING THE BIORETENTION FACILITY (WHERE APPLICABLE) IS NECESSARY TO PROMOTE THE AESTHETICS OF THE FACILITY. REGIONS IDENTIFIED AS "NO MOW AREAS" MUST REMAIN UNDISTURBED AND MUST NOT BE TRIMMED. A BRUSH TRIMMER SHOULD BE USED TO CUT DOWN BRUSH AND SHRUBS TO A MANAGEABLE HEIGHT ONCE ANNUALLY BETWEEN MARCH AND APRIL.

#### TRASH & DEBRIS REMOVAL

IN ADDITION TO IMPROVING THE AESTHETICS OF THE SYSTEM, ROUTINE TRASH AND DEBRIS REMOVAL MUST BE CONDUCTED TO MAINTAIN THE FUNCTIONALITY OF THE SYSTEM. ANY VISIBLE TRASH, SEDIMENT, AND DEBRIS MUST BE REMOVED FROM THE PLANTING BED, FOREBAYS, AND INLET/OUTLET FLOATABLE TRAPS DURING EACH INSPECTION TO PREVENT THE CLOGGING OF THE BIORETENTION MEDIA, REDUCTION OF WATER STORAGE VOLUME, AND TO ELIMINATE POTENTIAL HABITATS FOR VECTOR (MOSQUITO) LARVAE. ALL BIORETENTION FACILITY MEDIA AND COMPONENTS MUST BE INSPECTED TO ENSURE STORMWATER CAN MOVE THROUGH THE FACILITY AND DRAIN THROUGH BOTH THE BIORETENTION MEDIA AND THE OVERFLOW STRUCTURES, AS INTENDED. SUBSTANTIAL CLOGGING OF THE FACILITY MAY RESULT IN FLOODING CONCERNS IF WATER EXCEEDING THE BASIN CAPACITY IS UNABLE TO EXIT THE SITE THROUGH THE STORM SEWER SYSTEM. SOME BASIN OVERFLOW STRUCTURES MAY CONTAIN TRAPS USED TO COLLECT AND PREVENT TRASH AND OTHER FLOATABLE OBJECTS FROM ENTERING THE STORM SEWER SYSTEM. THESE TRAPS MUST BE REGULARLY BE EMPTIED TO ENSURE THEIR CONTINUED FUNCTIONALITY.

#### MINOR SEDIMENT/LEAF REMOVAL

ORGANIC MATTER, SUCH AS LEAF DEBRIS, MUST BE REMOVED FROM THE PLANTING AREAS TO PREVENT THE BIOSOIL LAYER FROM BECOMING CLOGGED, WHICH IS NECESSARY IN MAINTAINING THE SYSTEM'S ABILITY TO INFILTRATE AND TREAT STORMWATER. ROCK CHANNELS, INLET PROTECTION, AND OTHER STONE STRUCTURES WITHIN THE BASIN MUST BE REGULARLY BE CLEANED OF SEDIMENT TO CONTINUE THEIR FUNCTION OF REMOVING SUSPENDED SOLIDS FROM SURFACE FLOW. LEAF REMOVAL MUST BE CONDUCTED IF LEAF LITTER EXCEEDS FOUR (4) INCHES IN DEPTH OR IF THE ACCUMULATED LEAF DEBRIS IS IMPEDING THE FILTRATION OR FUNCTIONALITY OF THE SCP.

#### MINOR SOIL COMPACTION REPAIRS

THE SURFACE OF THE BASIN MUST BE INSPECTED FOR INDICATIONS OF SETTLING OR COMPACTION OF SURFACE

MATERIALS, WHICH WILL DECREASE SOIL POROSITY AND REDUCE INFILTRATION RATES. IF SOIL COMPACTION OR SETTLING IS OBSERVED, SURFACE MATERIALS MUST BE BROKEN UP USING HAND TOOLS TO INCREASE VOID SPACE.

#### MINOR EROSION REPAIRS

MINOR EROSION FROM SHEET FLOW ENTERING AND TRAVELING THROUGH THE BASIN MUST BE EVALUATED ALONG THE SIDE SLOPES AND BOTTOM OF THE BASIN. THIS CAN TYPICALLY BE IDENTIFIED AS REGIONS OF DISPLACED MULCH, GULLYING, OR UNVEGETATED AREAS ALONG THE SIDE SLOPES. IN PLANTED REGIONS OF THE BIORETENTION FACILITY, SURFACE MULCH MUST BE PLACED AND RAKED AROUND ALL PLANTS, AND REPLENISHED AS NEEDED, TO ENSURE ADEQUATE GROUND COVERAGE. DURING EACH INSPECTION, EXISTING SOIL AND MULCH MUST BE SPREAD OR SMOOTHED ALONG THE BASIN BOTTOM, WHICH WILL ASSIST IN WEED CONTROL AND EROSION PROTECTION DURING THE ESTABLISHMENT PERIOD. IN REGIONS OF HEAVILY CONCENTRATED FLOW, SUCH AS NEAR INLET STRUCTURES, MINOR REPAIRS TO ROCK STRUCTURES MUST BE CONDUCTED BY REARRANGING THE EXISTING STONE TO ENSURE COMPLETE COVERAGE, AS NECESSARY. ROUTINE ESTABLISHMENT PERIOD MAINTENANCE DOES NOT INCLUDE THE PLACEMENT OF NEW ROCK.

#### MULCH REPLACEMENT

IN ADDITION TO SPREADING OR SMOOTHING EXISTING MULCH TO ENSURE PROPER COVERAGE OF THE PLANTING AREA, MULCH MUST BE REPLACED ANNUALLY TO MAINTAIN AN ADEQUATE GROUND COVER OVER THE BIORETENTION MEDIA THROUGHOUT THE YEAR. IN ADDITION TO PREVENTING EROSION, A PROPER MULCH COVER WILL ASSIST IN WEED CONTROL.

#### PLANT PRUNING

IF SHRUBS, PERENNIALS OR TREES ARE PLANTED IN THE SCP, PRUNING MUST BE PERFORMED IN ORDER TO IMPROVE OR MAINTAIN THE HEALTH AND AESTHETICS OF THE VEGETATIVE SYSTEM. WOODY SPECIES REQUIRE PRUNING AND BRANCHES SHOULD BE INSPECTED TO REMOVE CROSSED OR DEAD BRANCHES. SHRUBS AND PERENNIALS REQUIRE PRUNING/DEAD HEADING TO ENCOURAGE NEW GROWTH AND PROMOTE THE HEALTH OF THE PLANTS.

### ROUTINE INSPECTION AND MAINTENANCE FOR BIORETENTION FACILITIES:

MONTHLY INSPECTIONS:

AFTER THE ESTABLISHMENT PERIOD, INSPECTIONS FOR BIORETENTION BASINS MUST CONTINUE TO BE PERFORMED MONTHLY. MONTHLY INSPECTIONS ARE REQUIRED FOR THE SERVICE LIFE OF THE BIORETENTION FACILITY. THE TASKS ARE THE SAME AS DURING THE ESTABLISHMENT PERIOD.

MAINTENANCE TASKS AND SCHEDULE:

ROUTINE MAINTENANCE INCLUDES:

- WEEDING (ONE/MONTH MARCH–OCTOBER)
- TRIMMING (ONE/WEEK MARCH–OCTOBER)
- TRASH & DEBRIS REMOVAL (ONCE/MONTH ALL YEAR)
- MINOR SEDIMENT/LEAF REMOVAL (ONCE/MONTH ALL YEAR)
- MINOR EROSION REPAIRS (ONCE/MONTH ALL YEAR)
- MULCH REPLACEMENT (ONCE IN FEBRUARY–MAY)
- PLANT PRUNING (ONCE IN MARCH–MAY AND ONCE IN NOVEMBER–DECEMBER)

### AS–NEEDED MAINTENANCE FOR BIORETENTION FACILITIES:

MAINTENANCE TASKS AND SCHEDULE:

AS–NEEDED MAINTENANCE INCLUDES:

- INLET/OUTLET STRUCTURE CLEANING (YEAR LONG)
- PLANT REPLACEMENT (MARCH–MAY AND SEPTEMBER–NOVEMBER)
- STAKE REPAIR/REPLACEMENT (YEAR LONG)
- WATERING DURING DROUGHT (MARCH–OCTOBER)
- ROCK CHANNEL REPLACEMENT (YEAR LONG)
- MEDIA REPLACEMENT (APRIL)
- MAJOR SEDIMENT/LEAF REMOVAL (YEAR LONG)
- MAJOR TRASH/DEBRIS REMOVAL (YEAR LONG)
- PEST/DISEASE/INVASIVE SPECIES MANAGEMENT (YEAR LONG)
- SOIL COMPACTION REPAIRS (YEAR LONG)

#### INLET/OUTLET STRUCTURE CLEANING

IN ORDER TO MAINTAIN THE FUNCTIONALITY OF THE BIORETENTION FACILITY, INLET AND OUTLET STRUCTURES MUST OCCASIONALLY BE CLEANED OF LARGE TRASH AND DEBRIS. BLOCKAGES MUST BE IDENTIFIED AND REMOVED BEFORE FLOW IS SEVERELY OBSTRUCTED FROM ENTERING OR EXITING THE FACILITY.

#### PLANT REPLACEMENT

FOLLOWING THE ESTABLISHMENT PERIOD, PLANT SURVIVABILITY MUST STABILIZE, AND PLANT REPLACEMENT MUST ONLY OCCUR AS-NEEDED. ANY PLANTS THAT DO NOT SURVIVE MUST BE REPLACED WITH THE IDENTICAL NUMBER OF PLANTS LOST AND SPECIES SPECIFIED ON THE PERMITTED PLANTING PLAN, IN ORDER TO MAINTAIN PROPER PLANTING DENSITY AND BIORETENTION FUNCTIONALITY AS A STORMWATER TREATMENT SYSTEM. IF A PLANT SURVIVABILITY STUDY HAS BEEN CONDUCTED TO IDENTIFY RECOMMENDED SPECIES SUBSTITUTIONS, PLANT REPLACEMENTS MUST BE MADE IN ACCORDANCE WITH THE APPROVED MODIFIED PLANTING PLAN. FOR CITY-OWNED SCPs, MODIFICATIONS TO THE PLANTING PLAN MUST BE APPROVED BY THE CITY OF COLUMBUS. IF EXTENSIVE PLANT REPLACEMENT IS REQUIRED IN CONJUNCTION WITH THE MEDIA REPLACEMENT, ESTABLISHMENT PERIOD MAINTENANCE MUST BE CONDUCTED. REFER TO THE CITY OF COLUMBUS SUPPLEMENTAL SPECIFICATION SS 1609 GREEN INFRASTRUCTURE ESTABLISHMENT ACTIVITIES AND CMSC 661 FOR ADDITIONAL DETAILS AND SCHEDULING REQUIREMENTS.

#### STAKE REPAIR/REPLACEMENT/REMOVAL

PLANT STAKES BROKEN OR DAMAGED DURING THE ESTABLISHMENT PERIOD MUST BE REPLACED TO ENSURE THE PROPER GROWTH AND ESTABLISHMENT OF THE AFFECTED PLANTS. ONCE PLANTS HAVE BECOME ESTABLISHED, STAKES MUST BE REMOVED FROM THE FACILITY TO PREVENT GIRDLING OR OTHER DAMAGE TO THE PLANTS.

#### WATERING DURING DROUGHT

MATURE PLANTS WILL NOT REQUIRE SCHEDULED WATERING AFTER THE INITIAL ESTABLISHMENT PERIOD. HOWEVER, WATERING MAY BE REQUIRED DURING EXTREME DROUGHT CONDITIONS TO ENSURE THE SURVIVAL OF THE VEGETATION WITHIN THE FACILITY. SOIL CRACKING AND PLANT DISTRESS ARE INDICATIVE OF DROUGHT. IF FRANKLIN COUNTY IS EXPERIENCING "ABNORMALLY DRY" OR "MODERATE DROUGHT" CONDITIONS AS INDICATED BY THE UNITED STATES DROUGHT MONITOR ([HTTP://DROUGHTMONITOR.UNL.EDU/](http://droughtmonitor.unl.edu/)) CONSULT WITH THE CITY OF COLUMBUS TO DETERMINE IF WATERING MUST BE PERFORMED AT CITY-OWNED SCPs.

#### ROCK CHANNEL REPLACEMENT

IN LOCATIONS OF CONTINUED EROSION, ADDITIONAL ROCK MAY BE REQUIRED TO REPLACE OR STRENGTHEN THE EXISTING EROSION CONTROL MEASURES. THIS COMMONLY OCCURS AT LOCATIONS OF HIGH FLOW VELOCITY, SUCH AS THE ROCK CHANNELS OR RIP-RAP SURROUNDING THE INLET STRUCTURES. SEVERE OR CONTINUED EROSION AND SETTLING MAY REQUIRE THE INSTALLATION OF MORE PERMANENT EROSION CONTROL OR SLOPE STABILITY MEASURES, SUCH AS RE-GRADING OF THE SCP OR INSTALLATION OF ENERGY DISSIPATION FEATURES.

#### MEDIA REPLACEMENT

BIORETENTION MEDIA MUST BE REPLACED IN LOCATIONS WHERE THE EXISTING SOIL HAS BEEN RELOCATED OR REMOVED FROM THE BASIN BOTTOM TO ENSURE THE SOIL REMAINS AT THE REQUIRED DEPTH FOR STORMWATER TREATMENT. FACILITIES EXPERIENCING SIGNIFICANT CLOGGING OF THE BIORETENTION MEDIA MAY REQUIRE COMPLETE REPLACEMENT OF THE EXISTING SOIL. IF EXTENSIVE PLANT REPLACEMENT IS REQUIRED IN CONJUNCTION WITH THE MEDIA REPLACEMENT, E ESTABLISHMENT PERIOD MAINTENANCE MUST BE CONDUCTED.

#### MAJOR SEDIMENT/LEAF REMOVAL

BIORETENTION FACILITIES THAT ARE EXPERIENCING SEVERE SEDIMENT OR LEAF ACCUMULATION MAY REQUIRE CLEANING AND DEBRIS REMOVAL EFFORTS BEYOND WHAT IS REGULARLY REQUIRED. STORMWATER MUST BE ABLE TO FREELY MOVE THROUGH THE FACILITY AND DRAIN THROUGH BOTH THE BIORETENTION MEDIA AND OVERFLOW STRUCTURES, AS INTENDED. THEREFORE, IT IS IMPORTANT TO KEEP ALL STRUCTURAL COMPONENTS AND SOIL MEDIA FREE OF BLOCKAGES. IF WATER EXCEEDING THE BASIN CAPACITY IS UNABLE TO EXIT THE SITE THROUGH THE STORM SEWER SYSTEM, SEVERE CLOGGING OF THE FACILITY MAY RESULT IN THE PROLIFERATION OF VECTOR (MOSQUITO) HABITAT, REDUCED WATER STORAGE VOLUME, OR FLOODING CONCERNS.

#### MAJOR TRASH & DEBRIS REMOVAL

IN ADDITION TO REGULAR FUNCTION OF THE FACILITY, REMOVAL OF EXCESSIVE DEBRIS ACCUMULATIONS MUST BE CONDUCTED ON AN AS-NEED BASIS TO IMPROVE THE OVERALL AESTHETICS OF THE FACILITY. WHEN MAJOR TRASH AND DEBRIS ARE PRESENT AT THE FACILITY (E.G. ILLEGAL DUMPING, LARGE DOWNED TREE BRANCHES) THESE ITEMS MUST BE REMOVED, AND SORTED FOR PROPER DISPOSAL (E.G. COMPOST, RECYCLING, WASTE).

#### PEST/DISEASE/INVASIVE SPECIES MANAGEMENT

BIORETENTION FACILITIES MUST BE CLOSELY MONITORED FOR THE ONSET OF PESTS, DISEASE, OR INVASIVE SPECIES, WHICH MUST BE PROMPTLY ADDRESSED IN ORDER TO MITIGATE POTENTIAL SPREADING TO NEARBY PLANTS OR BASINS. INVASIVE PLANT SPECIES MUST BE REMOVED ENTIRELY, INCLUDING ALL ROOTS AND ROOT FRAGMENTS, BEFORE THE PLANTS SET SEED. THESE PRACTICES WILL AID IN REDUCING FURTHER SPREAD OR ESTABLISHMENT OF THE UNWANTED SPECIES. WHEN MANAGING THE PROLIFERATION OF PESTS WITHIN A BIORETENTION FACILITY, IT IS IMPORTANT TO FIRST IDENTIFY THE UNDERLYING CAUSE OF THE ISSUE. IN SOME INSTANCES, COMPLETION OF AS-NEEDED MAINTENANCE TASKS MAY RESOLVE THE PEST ISSUE WITHOUT HAVING TO TAKE ADDITIONAL MEASURES. FOR EXAMPLE, IF THE AS-NEEDED MAINTENANCE ISSUE IS GENERATING FAVORABLE CONDITIONS FOR THE PEST TO INHABIT, SUCH AS VECTOR (MOSQUITO) POPULATIONS RESULTING FROM THE PROLONGED PONDING DUE TO CLOGGED OUTLET STRUCTURES, RETURNING THE BIORETENTION FACILITY TO ITS PROPERLY FUNCTIONING STATE MAY SUBSEQUENTLY ELIMINATE THE PEST. THE USE OF FERTILIZERS, PESTICIDES, AND HERBICIDES IS PROHIBITED DURING THE ESTABLISHMENT PERIOD OF BIORETENTION FACILITIES, AND STRONGLY DISCOURAGED FOLLOWING THE INITIAL ESTABLISHMENT PERIOD. HOWEVER, IF USE OF PESTICIDE IS REQUIRED (I.E. ALL OTHER OPTIONS HAVE BEEN EXPENDED TO ADDRESS AN ISSUE) APPROVAL MUST BE OBTAINED FROM THE CITY OF COLUMBUS, AND APPLICATIONS SHALL BE MADE IN ACCORDANCE WITH ALL APPLICABLE LOCAL, STATE, AND FEDERAL REGULATIONS BY A LICENSED APPLICATOR. PRODUCTS USED MUST BE APPROVED FOR AQUATIC USE.

#### SOIL COMPACTION REPAIRS

THE SURFACE OF THE BASIN MUST BE INSPECTED FOR INDICATIONS OF SETTLING OR COMPACTION OF SURFACE MATERIALS, WHICH WILL DECREASE SOIL POROSITY AND REDUCE INFILTRATION RATES. IF SOIL COMPACTION OR SETTLING IS OBSERVED, SURFACE MATERIALS MUST BE BROKEN UP USING HAND TOOLS TO INCREASE VOID SPACE.

#### SUMMARY OF POST CONSTRUCTION STORMWATER CONTROL FACILITIES

| CONTROL/OUTLET STRUCTURE NO. (AS REFERENCED ON PLANS) | PLAN VIEW & DETAIL PAGE NUMBERS FOR SCP | CONTROL FUNCTION   | DRAINAGE AREA TO CONTROL FACILITY (ACRE) | FACILITY TYPE | GREEN INFRASTRUCTURE (SQUARE FEET) |
|---|---|--------------------|--|---------------|------------------------------------|
| 11  | 14                                      | QUALITY & QUANTITY | 0.5                                      | BIORETENTION  | 3,706                              |

#### 100-YR DETENTION TABLE

| LOCATION              | VOLUME REQUIRED (C.F.) | VOLUME PROVIDED (C.F.) | ELEVATION | MAX ELEVATION | REMARKS |
|-----------------------|------------------------|------------------------|-----------|---------------|---------|
| BIORETENTION FACILITY | 61,078                 | 82,659                 | 781.88    | 783.00        |         |

#### ESTIMATE OF QUANTITIES

| ITEM | QUANTITY | UNIT | DESCRIPTION  |
|------|----------|------|--|
| 204  | 2,368    | SY   | GEOTEXTILE FABRIC  |
| 604  | 1        | EA   | STANDARD CATCH BASIN PER STD. DWG. AA-133B WITH OUTLET CONTROL STRUCTURE |
| 661  | 1,021    | EA   | PERENNIALS, 2-2.5', BLUE FLAG IRIS                                       |
| 661  | 1,904    | EA   | GROUNDCOVER, 2-2.5', TARA PRAIRIE DROPSEED                               |
| 915  | 2        | EA   | CLEANOUT   |
| 1602 | 2,912    | CY   | EXCAVATION FOR GREEN INFRASTRUCTURE FACILITIES                           |
| 1602 | 2,337    | SY   | SUBGRADE PREPARATION FOR GREEN INFRASTRUCTURE FACILITIES                 |
| 1604 | 9,315    | CF   | BIORETENTION SOIL  |
| 1609 | 1        | LS   | GREEN INFRASTRUCTURE PERIOD OF ESTABLISHMENT SEASON 2                    |
| 1610 | 91       | CY   | GREEN INFRASTRUCTURE AGGREGATE, TYPE B                                   |
| 1610 | 269      | FT   | 6" PIPE UNDERDRAINS FOR GREEN INFRASTRUCTURE                             |

CALCULATED

CHK  
CHECKED

LET

CIP NO.  
530303-10002

PID NO.  
N/A



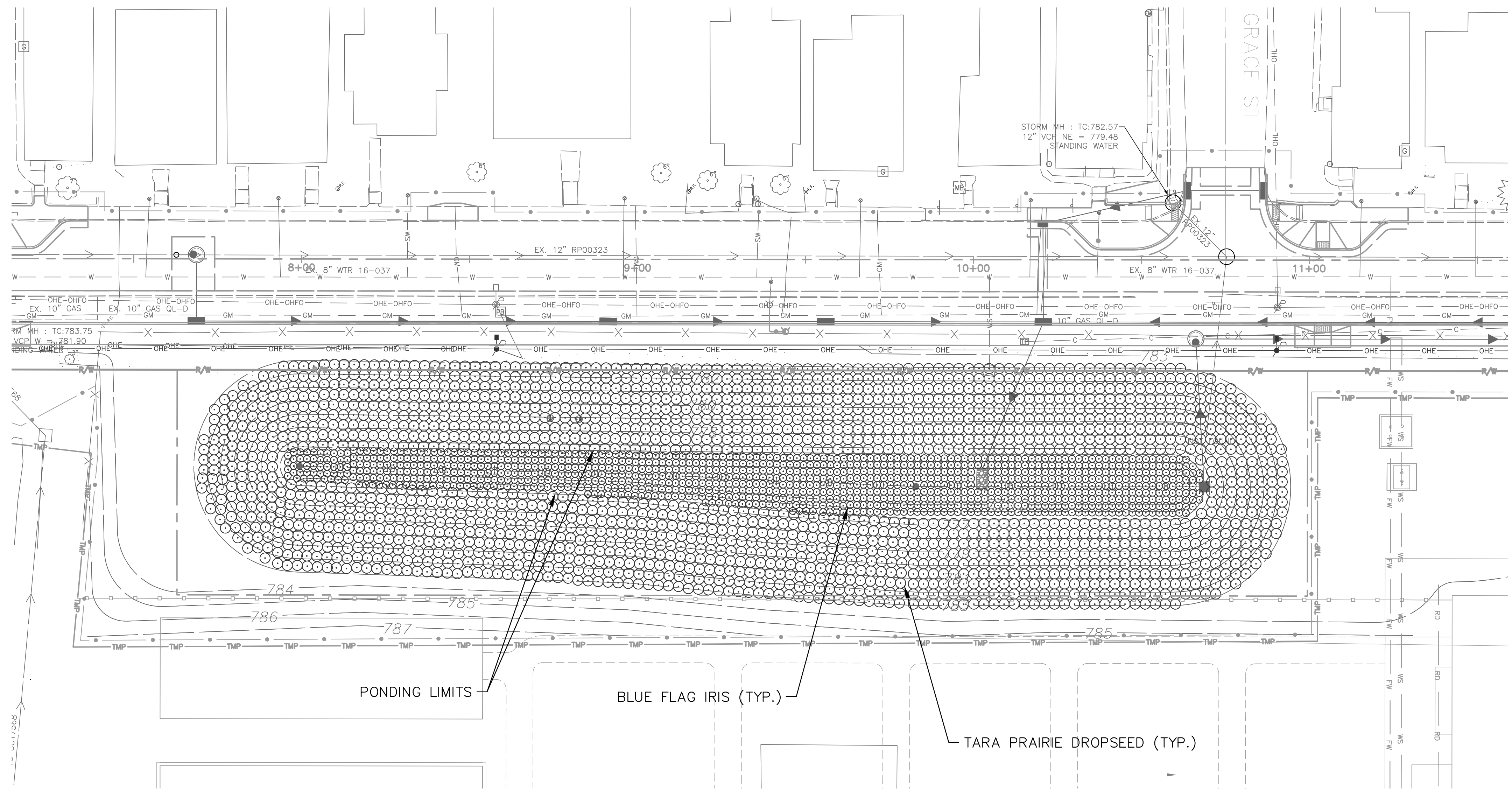

PLANT MATERIALS LIST

| QUANTITY | COMMON NAME           | BOTANICAL NAME                | HEIGHT | SPACING |
|----------|-----------------------|-------------------------------|--------|---------|
| 1,021    | BLUE FLAG IRIS        | IRIS VERSICOLOR               | 2-2.5' | 2'      |
| 1,904    | TARA PRAIRIE DROPSEED | SPOROBOLUS HETEROLEPIS 'TARA' | 2-2.5' | 3'      |

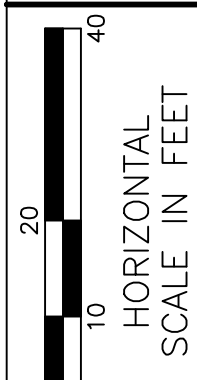
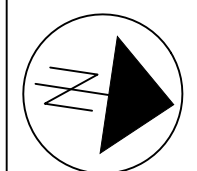

CALCULATED  
 CNK  
 CHECKED  
 LET

CIP NO.  
 530303-100002  
 PID NO.  
 N/A

**POST CONSTRUCTION STORMWATER CONTROL PRACTICE  
 BIORETENTION PLANTING PLAN**

**IMPROVEMENT OF WHEATLAND AVE**  
 FROM W BROAD STREET TO N OAKLEY AVENUE

**3813-E**