

# LEAK DETECTION GUIDE

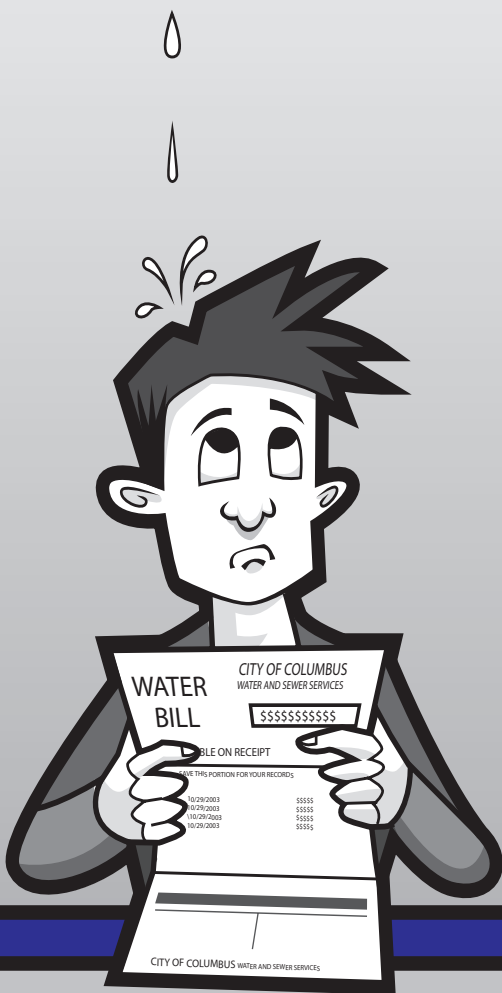

**Fix leaks, save  
water and money**

## Leak Detection Tips

To check for concealed leaks, there are two good do-it-yourself approaches:

### The Meter Check

Check all faucets, inside and outside, to make sure they are off. Find your inside water meter and mark the position of the test dial with a crayon or pen and write down the digits of the meter reading. Wait 20 minutes to one hour. Do not use any water during this time, and when the time is up, check the test dial on the meter to see if the hand has moved away from the mark you made. Also check the reading to see if it changed. If the hand has moved and/or the reading has changed, you have some type of leak.

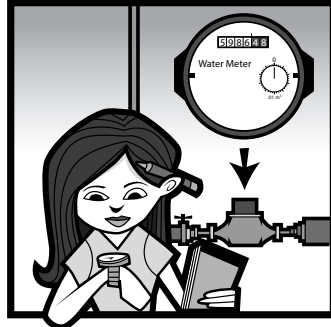

### Listen for Leaks

Check all faucets, inside and out, to make sure they are off. Take a large regular screwdriver (preferably 10" or longer) and firmly place it on the hot or cold side of any faucet.







Place your ear on the plastic handle and listen for water sounds. You can also do this test on any exposed pipes, valves or fittings. If you hear the sound of running water, you have a leak. Faucets, pipes and fittings should have no sound if there is no leak.

## Look for Faucet Leaks

All faucets, including those in the basement or storage areas, should be checked periodically. Most faucet and shower head leaks result from worn washers. Replace washers on dripping faucets and showers immediately. Even a small leak can waste several gallons of water a day and can add up on your water bill. Your water heating costs will also increase if it is a hot water leak.

### The Drip Chart

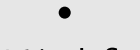
A continuous leak in the diameter sizes shown below at an average household water pressure of 60 psi (pounds per square inch) can result in these approximate water losses:

	<b>A dripping faucet wastes 1,500 gallons in 3 months</b> \$\$\$
	<b>Wastes 18,000 gallons in 3 months</b>
	<b>Wastes 70,000 gallons in 3 months</b>
	<b>Wastes 300,000 gallons in 3 months</b>
	<b>Wastes 1,000,000 gallons in 3 months</b>

## Check for Toilet Leaks

A leaking toilet is one of the most common water wasters, but toilet leaks are less noticeable than faucet leaks. Here are some simple tests that you can use to see if you have a toilet leak:

Flush the toilet. Wait for the toilet to stop refilling, then make a visual inspection of the bowl. If water is still running into the bowl, or if water can be heard, your toilet is leaking.



Remove the toilet tank lid and check the water level in the tank. The water level should come up to 1" or so below the opening to the overflow pipe. If the water level is too high, water can flow continuously down the overflow tube. If the water level is even with the top of the overflow tube, try sprinkling a little powder on the surface of the water. If you see the powder go down the overflow tube, the toilet is leaking.

Although water may not be seen or heard running, your toilet may have a silent leak. Try conducting this simple experiment. Take the lid off the toilet tank and add a couple drops of food coloring to the water in the tank. Do not flush. Wait 15 minutes. If the dye shows up in the toilet bowl, your toilet has a leak. The plunger ball or flapper probably needs to be cleaned or replaced, or there could be a crack in the overflow tube.

Check the operation of the flush handle. Take the lid off the toilet tank and flush the toilet. Make sure that the handle mechanisms operate smoothly and don't hang-up or jam. Check the chain that goes from the handle mechanism to the flapper at the bottom of the tank. The chain can get caught under the flapper if it is too long. A sticking handle can keep the flapper or float ball from completely closing off the bottom drain and the result can be a huge water and sewer bill.

## Toilet Troubleshooting

Check your toilets for leaks at least twice a year:

### A. Overflow Tube

The tank water level should be 1" below the opening of this tube. If the level is higher, water can leak down the tube. Adjust the water level with the adjustment screw or adjustment clip.

### B. Toilet Float

These floats can wear out in 2 to 7 years, faster if you use chemicals in the tank. Replace yours if it's cracked or waterlogged.

### C. Flush Valve Bulb or Flapper

These rubber valves may not seal completely, causing water to leak around them. Clean, repair or replace faulty flush valves.

### D. Handle

The handle controls the lifting and lowering of the flapper or bulb. Tighten a loose handle or straighten the control arm if it is rubbing. Check all connections for smooth operation. When the toilet is flushed, make sure nothing catches under the flapper.

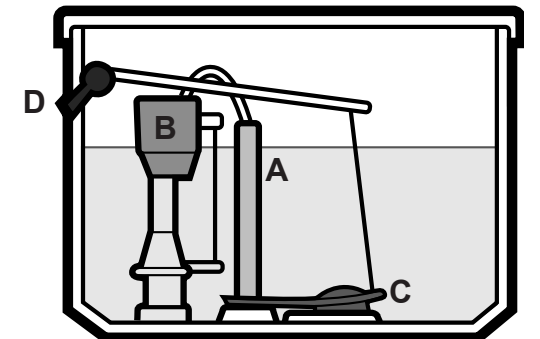
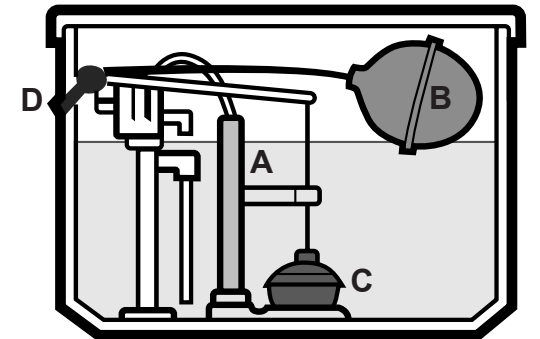

### Check Your Meter and Outside Register

It's also recommended that you check your meter and outside remote register twice a year to make sure they match. Locate each unit and record all numbers with the same color background from left to right. If the readings differ by more than three digits, please call Customer Service 614-645-8276.

In this example, the meter (left) reads 5986 and the remote (right) matches.

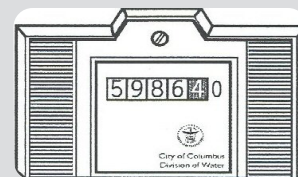

## Check Your Service Line

Your service line is the pipe that connects your house to the city's water main. It's buried about 42" underground (below the frost line) to keep it from freezing in the winter. A service line leak will not increase your bill, but repairs to the owner's line can be expensive.

Find your curb box, the metal cylinder that allows access to the valve that controls the water flow from the main to your house. Look for the lid in your yard, sidewalk or driveway. It is usually made of cast iron, is about 5" in diameter and typically says "WATER." Call 614-645-8276 if you see water seeping from your curb box.

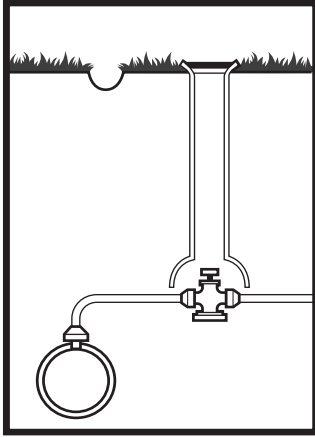

### Other Signs of a Homeowner Service Line Leak:

Look at the walls where your service line enters the house (illustrated below). Look for discoloration, moisture and sponginess. At the same time, check to see if your main control valve (located next to your water meter) is leaking. Repairs to this valve are the owner's responsibility, although we will turn off water free of charge so that the repair can be completed. If the meter is leaking, call us at 614-645-8276.

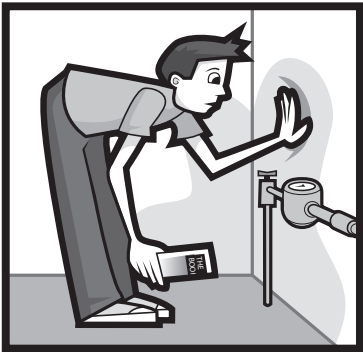

Check the building foundation for cracking, vegetation growing unevenly or heaving of the earth for no apparent reason.

Look for a soft spot or depression in your yard, often accompanied by a drop in household water pressure.

## Outside Water Taps

Periodically check outside taps for leaks, especially during the summer watering season. A hose mistakenly left on can dribble away thousands of gallons of water over a summer season. Remember to close outside faucets tightly.

Outside taps can freeze in frigid winter temperatures. A frozen spigot can crack or burst and turn your yard into a lake of ice. If your house does not have frost proof spigots, be sure to turn water off at the valve on the line that supplies the outside tap.

## Other Places to Look for Leaks

**Humidifier** - A humidifier needs a continuous supply of water, often supplied by a line or tubing plumbed directly into the mechanism. Control valves can stick open, causing water to flow through the humidifier.

**Ice Maker** - Automatic refrigerator ice-makers also have supply lines or tubing. This tubing can spring a leak, sometimes even inside a wall.

**Water Softener** - Control valves can stick on water softeners, causing them to continuously recharge. Supply lines can spring leaks.

**Underground Lines** - Some homes and businesses have plumbing lines running from one building to another or to a detached garage or storage building. Breaks on these lines are difficult to find. Watch for wet spots or ground erosion near where lines are located or listen on the line that goes underground to hear if water is leaking.

**Swimming Pool** - To check your pool for a leak, fill a five gallon plastic bucket to approximately 1" from the top with pool water and mark the water level in the bucket. Mark the normal water level on the pool with tape, a wax pencil or crayon. Turn off all water filling devices. Place the bucket on a step in the pool and wait 24 hours. If the water level in the pool drops more than the water level in the bucket, you have a leak. If needed, please contact a pool contractor who specializes in detecting swimming pool leaks.

**Hot Water Tank** - Water heaters can spring leaks at the fittings or from the drain valve at the bottom of the tank. Also, corrosion can eat through the inside liner. Leakage from a hot water tank can go undetected for a long time if the tank is in a basement with a floor drain. A higher than normal electric or gas bill could be caused by a hot water tank leak.

**Sprinkler System** - In-ground sprinkler systems can spring leaks that are very difficult to find. Be sure to drain your system before cold winter temperatures freeze the lines and cause leaks.

Fix all leaks immediately. Some plumbing repairs, such as replacing faucet washers or toilet parts, can be done by a handy do-it-yourselfer. If you're not handy, please contact a licensed plumber. To learn more about conserving water and other resources, please visit our website below and consider joining GreenSpot.

